

INTERNATIONAL STANDARD

**Lightning protection system components (LPSC) –
Part 2: Requirements for conductors and earth electrodes**





THIS PUBLICATION IS COPYRIGHT PROTECTED

Copyright © 2012 IEC, Geneva, Switzerland

All rights reserved. Unless otherwise specified, no part of this publication may be reproduced or utilized in any form or by any means, electronic or mechanical, including photocopying and microfilm, without permission in writing from either IEC or IEC's member National Committee in the country of the requester.

If you have any questions about IEC copyright or have an enquiry about obtaining additional rights to this publication, please contact the address below or your local IEC member National Committee for further information.

IEC Central Office
3, rue de Varembe
CH-1211 Geneva 20
Switzerland

Tel.: +41 22 919 02 11
Fax: +41 22 919 03 00
info@iec.ch
www.iec.ch

About the IEC

The International Electrotechnical Commission (IEC) is the leading global organization that prepares and publishes International Standards for all electrical, electronic and related technologies.

About IEC publications

The technical content of IEC publications is kept under constant review by the IEC. Please make sure that you have the latest edition, a corrigenda or an amendment might have been published.

Useful links:

IEC publications search - www.iec.ch/searchpub

The advanced search enables you to find IEC publications by a variety of criteria (reference number, text, technical committee,...).

It also gives information on projects, replaced and withdrawn publications.

IEC Just Published - webstore.iec.ch/justpublished

Stay up to date on all new IEC publications. Just Published details all new publications released. Available on-line and also once a month by email.

Electropedia - www.electropedia.org

The world's leading online dictionary of electronic and electrical terms containing more than 30 000 terms and definitions in English and French, with equivalent terms in additional languages. Also known as the International Electrotechnical Vocabulary (IEV) on-line.

Customer Service Centre - webstore.iec.ch/csc

If you wish to give us your feedback on this publication or need further assistance, please contact the Customer Service Centre: csc@iec.ch.



IEC 62561-2

Edition 1.0 2012-02

INTERNATIONAL STANDARD

**Lightning protection system components (LPSC) –
Part 2: Requirements for conductors and earth electrodes**

INTERNATIONAL
ELECTROTECHNICAL
COMMISSION

PRICE CODE



ICS 29.020; 91.120.40

ISBN 978-2-88912-924-9

Warning! Make sure that you obtained this publication from an authorized distributor.

CONTENTS

FOREWORD.....	4
INTRODUCTION.....	6
1 Scope.....	7
2 Normative references	7
3 Terms and definitions	8
4 Requirements	9
4.1 General	9
4.2 Documentation	9
4.3 Air termination conductors, air termination rods, earth lead-in rods and down conductors	9
4.4 Earth electrodes	11
4.4.1 General	11
4.4.2 Earth rods	11
4.4.3 Joints for earth rods.....	11
4.4.4 Earth conductors and plates	12
4.5 Marking	12
5 Tests	15
5.1 General conditions for tests.....	15
5.2 Conductors, air termination rods and earth lead-in rods.....	15
5.2.1 General	15
5.2.2 Tests for thickness coating on conductors	15
5.2.3 Bend and adhesion test for coated conductors	15
5.2.4 Environmental test.....	16
5.2.5 Tensile tests.....	16
5.2.6 Electrical resistivity test	16
5.3 Earth rods	17
5.3.1 General	17
5.3.2 Tests for thickness coating on earth rods.....	17
5.3.3 Adhesion test	18
5.3.4 Bend test.....	18
5.3.5 Environmental test.....	19
5.3.6 Tensile strength tests	19
5.3.7 Test for yield/tensile ratio	19
5.3.8 Electrical resistivity test	20
5.4 Joints for earth rods	21
5.4.1 General	21
5.4.2 Compression tests by mechanical means	21
5.4.3 Environmental – Electrical tests.....	22
5.5 Marking test	23
5.5.1 General conditions for tests.....	23
5.5.2 Acceptance criteria.....	23
6 Electromagnetic compatibility (EMC)	23
7 Structure and content of the test report	23
7.1 General	23
7.2 Report identification	24
7.3 Specimen description	24

7.4	Conductor	24
7.5	Standards and references	24
7.6	Test procedure	24
7.7	Testing equipment, description	24
7.8	Measuring instruments description	24
7.9	Results and parameters recorded	25
7.10	Statement of pass/fail	25
Annex A (normative)	Environmental test for conductors, air termination rods and earth lead-in rods	26
Annex B (normative)	Requirements for the cross sectional area, mechanical and electrical characteristics, tests to be applied	27
Annex C (normative)	Requirements for dimensions, mechanical and electrical characteristics, tests to be applied	28
Annex D (informative)	Typical example calculation of conductor resistivity	29
Annex E (informative)	Typical example of calculation of the tensile strength of a coated material	30
Annex F (normative)	Flow chart of tests for air termination conductors, air termination rods, earth lead-in rods and down conductors	31
Annex G (normative)	Flow chart of tests for earth rods	32
Annex H (normative)	Flow chart of tests of joints for earth rods	33
	Bibliography	34
Figure 1	– Coating measurements around the circumference of the rod	17
Figure 2	– Typical test arrangement for adhesion test	18
Figure 3	– Definitions of upper yield strength R_{eH} (Mpa) and tensile strength R_m (Mpa)	20
Figure 4	– Typical test arrangement for the compression test by mechanical means	22
Table 1	– Material, configuration and cross sectional area of air termination conductors, air termination rods, earth lead-in rods and down conductors	10
Table 2	– Mechanical and electrical characteristics of air termination conductors, air termination rods, earth lead-in rods and down conductors	11
Table 3	– Material, configuration and cross sectional area of earth electrodes	13
Table 4	– Mechanical and electrical characteristics of earth electrodes	14
Table B.1	– Summary of requirements for various elements tested according to Table 1 and Table 2	27
Table C.1	– Summary of requirements for various elements tested according to Table 3 and Table 4	28

INTERNATIONAL ELECTROTECHNICAL COMMISSION

LIGHTNING PROTECTION SYSTEM COMPONENTS (LPSC) –**Part 2: Requirements for conductors and earth electrodes**

FOREWORD

- 1) The International Electrotechnical Commission (IEC) is a worldwide organization for standardization comprising all national electrotechnical committees (IEC National Committees). The object of IEC is to promote international co-operation on all questions concerning standardization in the electrical and electronic fields. To this end and in addition to other activities, IEC publishes International Standards, Technical Specifications, Technical Reports, Publicly Available Specifications (PAS) and Guides (hereafter referred to as "IEC Publication(s)"). Their preparation is entrusted to technical committees; any IEC National Committee interested in the subject dealt with may participate in this preparatory work. International, governmental and non-governmental organizations liaising with the IEC also participate in this preparation. IEC collaborates closely with the International Organization for Standardization (ISO) in accordance with conditions determined by agreement between the two organizations.
- 2) The formal decisions or agreements of IEC on technical matters express, as nearly as possible, an international consensus of opinion on the relevant subjects since each technical committee has representation from all interested IEC National Committees.
- 3) IEC Publications have the form of recommendations for international use and are accepted by IEC National Committees in that sense. While all reasonable efforts are made to ensure that the technical content of IEC Publications is accurate, IEC cannot be held responsible for the way in which they are used or for any misinterpretation by any end user.
- 4) In order to promote international uniformity, IEC National Committees undertake to apply IEC Publications transparently to the maximum extent possible in their national and regional publications. Any divergence between any IEC Publication and the corresponding national or regional publication shall be clearly indicated in the latter.
- 5) IEC itself does not provide any attestation of conformity. Independent certification bodies provide conformity assessment services and, in some areas, access to IEC marks of conformity. IEC is not responsible for any services carried out by independent certification bodies.
- 6) All users should ensure that they have the latest edition of this publication.
- 7) No liability shall attach to IEC or its directors, employees, servants or agents including individual experts and members of its technical committees and IEC National Committees for any personal injury, property damage or other damage of any nature whatsoever, whether direct or indirect, or for costs (including legal fees) and expenses arising out of the publication, use of, or reliance upon, this IEC Publication or any other IEC Publications.
- 8) Attention is drawn to the Normative references cited in this publication. Use of the referenced publications is indispensable for the correct application of this publication.
- 9) Attention is drawn to the possibility that some of the elements of this IEC Publication may be the subject of patent rights. IEC shall not be held responsible for identifying any or all such patent rights.

International Standard IEC 62561-2 has been prepared by IEC technical committee 81: Lightning protection.

The text of this standard is based on the following documents:

FDIS	Report on voting
81/417/FDIS	81/423/RVD

Full information on the voting for the approval of this standard can be found in the report on voting indicated in the above table.

This publication has been drafted in accordance with the ISO/IEC Directives, Part 2.

The content of this document is taken from the European Standard EN 50164-2.

A list of all the parts in the IEC 62561 series, published under the general title *Lightning protection system components (LPSC)*, can be found on the IEC website.

The committee has decided that the contents of this publication will remain unchanged until the stability date indicated on the IEC web site under "<http://webstore.iec.ch>" in the data related to the specific publication. At this date, the publication will be

- reconfirmed,
- withdrawn,
- replaced by a revised edition, or
- amended.

A bilingual version of this publication may be issued at a later date.

INTRODUCTION

This part of IEC 62561 deals with the requirements and tests for lightning protection system components (LPSC) used for the installation of a lightning protection system (LPS) designed and implemented according to the IEC 62305 series of standards.

LIGHTNING PROTECTION SYSTEM COMPONENTS (LPSC) –

Part 2: Requirements for conductors and earth electrodes

1 Scope

This part of IEC 62561 specifies the requirements and tests for:

- metallic conductors (other than “natural” conductors) that form part of the air termination system and down conductors;
- metallic earth electrodes that form part of the earth termination system.

2 Normative references

The following documents, in whole or in part, are normatively referenced in this document and are indispensable for its application. For dated references, only the edition cited applies. For undated references, the latest edition of the referenced document (including any amendments) applies.

IEC 60068-2-52:1996, *Environmental testing – Part 2-52: Tests – Test Kb: Salt mist, cyclic (sodium chloride solution)*

IEC 60228, *Conductors of insulated cables*

IEC 62305-3, *Protection against lightning – Part 3: Physical damage to structures and life hazard*

IEC 62305-4, *Protection against lightning – Part 4: Electrical and electronic systems within structures*

IEC 62561-1, *Lightning protection system components (LPSC) – Part 1: Requirements for connection components*

ISO 1460, *Metallic coatings – Hot dip galvanized coatings on ferrous materials – Gravimetric determination of the mass per unit area*

ISO 1461, *Hot dip galvanized coatings on fabricated iron and steel articles – Specifications and test methods*

ISO 2178, *Non-magnetic coatings on magnetic substrates – Measurement of coating thickness – Magnetic method*

ISO 6892-1:2009, *Metallic materials – Tensile testing – Part 1: Method of test at room temperature*

ISO 6957:1988, *Copper alloys – Ammonia test for stress corrosion resistance*

ISO 6988:1985, *Metallic and other non-organic coatings – Sulphur dioxide test with general condensation of moisture*

3 Terms and definitions

For the purpose of this document, the following terms and definitions apply.

3.1

air termination system

part of an external LPS using metallic elements such as rods, mesh conductors or catenary wires intended to intercept lightning flashes

3.2

air termination rod

air termination conductor

part of the air termination system for intercepting and conducting direct lightning flashes to the structure

3.3

down conductor

part of an external lightning protection system which is intended to conduct lightning current from the air termination system to the earth termination system

3.4

earth termination system

part of an external lightning protection system which is intended to conduct and disperse lightning current to the earth

3.5

earth electrode

part or group of parts of the earth termination system which provides direct electrical contact with and disperses the lightning current to the earth

Note 1 to entry Typical examples are earth rod, earth conductor and earth plate.

3.6

earth rod

an earth electrode consisting of a metal rod driven into the ground

[IEC 60050-604:1987, 604-04-09]

3.7

earth conductor

earth electrode consisting of a conductor buried in the ground

3.8

earth plate

an earth electrode consisting of a metal plate buried in the ground

[IEC 60050-604:1987, 604-04-10]

3.9

joint for earth rod

part of the earth termination system that facilitates the coupling of one section of an earth rod to another for the purpose of deep driving

3.10

driving head

tool used in those applications where it is necessary to drive the earth rod

3.11

earth lead-in rod

rod installed between the down conductor/test joint and the earth electrode

Note 1 to entry Earth lead-in rods are used to improve mechanical stability.

4 Requirements

4.1 General

Conductors and earth electrodes shall be so designed and constructed that in normal use their performance is reliable and without danger to persons and surrounding equipment.

The choice of a material depends on its ability to match the particular application requirements.

A summary of the requirements and their corresponding tests are given in Annex F, Annex G and Annex H.

4.2 Documentation

The manufacturer or supplier of the conductors and earth electrodes shall provide adequate information in their literature to ensure that the installer of the conductors and earth electrodes can select and install the materials in a suitable and safe manner, in accordance with IEC 62305-3 and IEC 62305-4.

Compliance is checked by inspection.

4.3 Air termination conductors, air termination rods, earth lead-in rods and down conductors

The material, configuration and cross sectional area of the conductors and rods shall be in accordance with Table 1. Their mechanical and electrical characteristics shall be in accordance with Table 2.

Other materials may be used if they possess equivalent mechanical and electrical characteristics and corrosion resistance properties for the intended application.

Other configurations may be used if the relevant dimensions are met.

Coated conductors and rods shall be corrosion resistant and the coating shall exhibit good adherence to the base material.

Compliance is checked by the tests described in 5.2.2, 5.2.3 and 5.2.4.

NOTE A summary of the requirements for the cross sectional area, mechanical and electrical characteristics as well as tests is given in Annex B.

Table 1 – Material, configuration and cross sectional area of air termination conductors, air termination rods, earth lead-in rods and down conductors

Material	Configuration	Cross sectional area ^a mm ²	Recommended dimensions
Copper, Tin plated copper ^b	Solid tape	≥ 50	2 mm thickness
	Solid round ^d	≥ 50	8 mm diameter
	Stranded ^{d, g}	≥ 50	1,7 mm diameter of each strand ^f
	Solid round	≥ 176	15 mm diameter
Aluminium	Solid tape	≥ 70	3 mm thickness
	Solid round	≥ 50	8 mm diameter
	Stranded ^g	≥ 50	1,63 mm diameter of each strand
Copper coated aluminium alloy ^e	Solid round	≥ 50	8 mm diameter
Aluminium alloy	Solid tape	≥ 50	2,5 mm thickness
	Solid round	≥ 50	8 mm diameter
	Stranded ^g	≥ 50	1,7 mm diameter of each strand
	Solid round	≥ 176	15 mm diameter
Hot dipped galvanized steel	Solid tape	≥ 50	2,5 mm thickness
	Solid round	≥ 50	8 mm diameter
	Stranded ^g	≥ 50	1,7 mm diameter of each strand
	Solid round	≥ 176	15 mm diameter
Copper coated steel ^e	Solid round	≥ 50	8 mm diameter
	Solid tape	≥ 50	2,5 mm thickness
Stainless steel ^c	Solid tape	≥ 50	2 mm thickness
	Solid round	≥ 50	8 mm diameter
	Stranded ^g	≥ 70	1,7 mm diameter of each strand
	Solid round	≥ 176	15 mm diameter

NOTE For the application of the conductors, see IEC 62305-3.

^a Manufacturing tolerance: –3 %.

^b Hot dipped or electroplated; minimum thickness coating of 1 µm. Tin plating is for aesthetic reasons only.

^c Chromium ≥ 16 %; nickel ≥ 8 %; carbon ≤ 0,08 %.

^d 50 mm² (8 mm diameter) may be reduced to 25 mm² (6 mm diameter) in certain applications where mechanical strength is not an essential requirement.

^e Minimum 70 µm radial copper coating of 99,9 % copper content.

^f In some countries 1,14 mm diameter of each strand may be used.

^g The cross sectional area of stranded conductors is determined by the resistance of the conductor according to IEC 60228.

Table 2 – Mechanical and electrical characteristics of air termination conductors, air termination rods, earth lead-in rods and down conductors

Material	Maximum electrical resistivity $\mu\Omega\text{m}$	Tensile strength N/mm^2
Copper	0,019	200 to 450
Aluminium	0,03	≤ 150
Aluminium alloy	0,036	120 to 280
Steel	0,15	290 to 510
Stainless steel	0,80	400 to 770

4.4 Earth electrodes

4.4.1 General

The cross sectional area of earth electrodes, its material and its configuration shall be in accordance with Table 3. Its mechanical and electrical characteristics shall be in accordance with Table 4.

Other materials may be used if they possess equivalent mechanical and electrical characteristics and corrosion resistance properties for the intended application.

Other configurations may be used if the relevant dimensions are met.

NOTE A summary of the requirements for dimensions, mechanical and electrical characteristics as well as tests is given in Annex C.

4.4.2 Earth rods

Earth rods shall be mechanically robust to ensure correct installation. The choice of material shall be sufficiently malleable to ensure no cracking of the rod takes place during installation.

The threads on the rods, if any, shall be smooth and fully formed. For coated rods, the coating shall extend over the threads. A lead-in chamfer or point is recommended to facilitate driving.

For electroplated rods such as copper coated rods, it is desirable to thread roll the thread profile to ensure no copper is removed from the steel.

Compliance is checked by inspection and by the test according to 5.3.

4.4.3 Joints for earth rods

Earth rods can be extended to drive deeper into the ground. This can be achieved by means of a joint/coupling device.

The choice of material shall be compatible with that of the earth rod being joined.

It shall be mechanically robust, sufficient to withstand the driving forces generated during installation.

It shall also exhibit good corrosion resistance.

Threaded external joints/couplers shall be of a sufficient length to ensure no threads on the earth rod are exposed when installed.

Threaded internal joints/couplers shall ensure that the mating faces of the earth rods come in contact after assembly.

Compliance is checked by the test of 5.4.2 and 5.4.3.

4.4.4 Earth conductors and plates

Earth electrode conductors and plates shall be corrosion resistant and any coating shall exhibit good adherence to the base material.

Compliance is checked by the test of 5.2.2, 5.2.3 and 5.2.4.

4.5 Marking

All products complying with this standard shall be marked at least with the following:

- a) manufacturer's or responsible vendor's name or trade mark;
- b) identifying symbol.

Where this proves to be impractical, the marking in accordance with the identifying symbol may be given on the smallest packing unit.

NOTE Marking can be applied for example by moulding, pressing, engraving, printing adhesive labels or water slide transfers.

Compliance is checked in accordance with 5.5.

Table 3 – Material, configuration and cross sectional area of earth electrodes

Material	Configuration	Cross sectional area ^a			Recommended dimensions
		Earth rod mm ²	Earth conductor mm ²	Earth plate cm ²	
Copper, tin plated copper ^f	Stranded		≥ 50 ⁱ		1,7 mm diameter of each strand
	Solid round		≥ 50		8 mm diameter
	Solid tape		≥ 50		2 mm thick
	Solid round	≥ 176			15 mm diameter
	Pipe	≥ 110			20 mm diameter with 2 mm wall thickness
	Solid plate			≥ 2 500	500 mm × 500 mm with 1,5 mm thickness ^g
	Lattice plate ^g			≥ 3 600	600 mm × 600 mm consisted of 25 mm × 2 mm section for tape or 8 mm diameter for round conductor
Hot dipped galvanized steel	Solid round		≥ 78		10 mm diameter
	Solid round	≥ 150 ^b			14 mm diameter
	Pipe	≥ 140 ^b			25 mm diameter with 2 mm wall thickness
	Solid tape		≥ 90		3 mm thick
	Solid plate			≥ 2 500	500 mm × 500 mm with 3 mm thickness
	Lattice plate ^d			≥ 3 600	600 mm × 600 mm consisted of 30 mm × 3 mm section for tape or 10 mm diameter for round conductor
	Profile	^e			3 mm thick
Bare steel	Stranded		≥ 70		1,7 mm diameter of each strand
	Solid round		≥ 78		10 mm diameter
	Solid tape		≥ 75		3 mm thick
Copper coated steel ^c	Solid round	≥ 150 ^h			14 mm diameter, if 250 μm minimum radial copper coating, with 99,9 % copper content
	Solid round		≥ 50		8 mm diameter, if 250 μm minimum radial copper coating, with 99,9 % copper content
	Solid round		≥ 78		10 mm diameter, if 70 μm minimum radial copper coating, with 99,9 % copper content
	Solid tape		≥ 90		3 mm thickness, if 70 μm minimum radial copper coating, with 99,9 % copper content
Stainless steel	Solid round		≥ 78		10 mm diameter
	Solid round	≥ 176 ^h			15 mm diameter
	Solid tape		≥ 100		2 mm thick

NOTE For the application of the conductors, see IEC 62305-3.

- ^a Manufacturing tolerance: –3 %.
- ^b Threads, where utilized, shall be machined prior to galvanizing.
- ^c The copper shall be intrinsically bonded to the steel. The coating can be measured using an electronic coating measuring thickness instrument.
- ^d Lattice plate constructed with a minimum total conductor length of 4,8 m.
- ^e Different profiles are permitted with a cross sectional area of 290 mm² and a minimum thickness of 3 mm, e.g. cross profile.
- ^f Hot dipped or electroplated; minimum thickness coating of 1 µm. Tin plating is for aesthetic reasons only.
- ^g In some countries, the cross sectional area may be reduced to ≥ 1 800 cm² and the thickness to ≥ 0,8 mm.
- ^h In some countries, the cross sectional area may be reduced to 125 mm².
- ⁱ The cross sectional area of stranded conductors is determined by the resistance of the conductor according to IEC 60228.

Table 4 – Mechanical and electrical characteristics of earth electrodes

Material	Configuration	Tensile strength N/mm ²			Maximum electrical resistivity µΩm
		Earth rod	Earth conductor	Earth plate	
Copper	Stranded	N/A	200 to 450	N/A	0,019
	Solid round	200 to 450	200 to 450	N/A	
	Solid tape	N/A	200 to 450	N/A	
	Pipe	200 to 450	N/A	N/A	
	Solid plate	N/A	N/A	200 to 450	
	Lattice plate	N/A	N/A	200 to 450	
Steel	Galvanized solid round	350 to 770	290 to 510	N/A	0,25
	Galvanized pipe	350 to 770	N/A	N/A	
	Galvanized solid tape	N/A	290 to 510	N/A	
	Galvanized solid plate	N/A	N/A	290 to 510	
	Galvanized lattice plate	N/A	N/A	290 to 510	
	Bare solid round	N/A	290 to 510	N/A	
	Bare or galvanized solid tape	N/A	290 to 510	N/A	
	Galvanized stranded	N/A	290 to 510	N/A	
	Galvanized cross profile	300 to 770	N/A	N/A	
	Copper coated solid round	600 to 770 ^{a, c}	290 to 510 ^c	N/A	
Stainless steel	Solid round ^b	500 to 770	400 to 730	N/A	0,80
	Solid tape ^b	N/A	400 to 730	N/A	

^a Yield/tensile ratio 0,80 to 0,95.
^b Chromium ≥ 16 %, nickel ≥ 5 %, molybdenum ≥ 2 %, carbon ≤ 0,08 %.
^c Calculated on full diameter (copper coating included). See Annex E.
N/A = not applicable

5 Tests

5.1 General conditions for tests

Tests according to this standard are type tests.

- Unless otherwise specified all tests are carried out on new specimens.
- Unless otherwise specified, three specimens are subjected to the tests and the requirements are satisfied if all the tests are met.
- If only one of the specimens does not satisfy a test due to an assembly or a manufacturing fault, that test and any preceding one which may have influenced the results of the test shall be repeated. The tests which follow shall also be carried out in the required sequence on another full set of specimens, all of which shall comply with the requirements.

The applicant, when submitting a set of specimens, may also submit an additional set of specimens which may be necessary should one specimen fail. The testing station will then, without further request, test the additional set of specimens and will reject only if a further failure occurs. If the additional set of specimens is not submitted at the same time, the failure of one specimen will entail rejection.

5.2 Conductors, air termination rods and earth lead-in rods

5.2.1 General

Air termination conductors, air termination rods, earth lead-in rods, down conductors and earth conductors shall be subjected to the following tests to confirm their suitability for the intended application.

5.2.2 Tests for thickness coating on conductors

5.2.2.1 General conditions for tests

Specimens each approximately 200 mm long shall be subjected to a test for galvanized and copper coated coating thickness.

The zinc and copper coating on a steel conductor shall be measured in accordance with ISO 1460. It can also be measured in accordance with ISO 1461 or ISO 2178.

There is no requirement to measure the tin plated copper due to the very small coating thickness. Only a visual inspection is required.

5.2.2.2 Acceptance criteria

The specimens are deemed to have passed the tests if they comply with the requirements of Table 1 for air termination conductors, air termination rods, earth lead-in rods, down conductors and Table 3 for earth electrodes. Additionally, the zinc galvanizing coating shall be smooth, continuous and free from flux stains with a minimum weight of 350 g/m² for solid round material and 500 g/m² for solid tape material.

5.2.3 Bend and adhesion test for coated conductors

5.2.3.1 General conditions for tests

Coated conductors each approximately 500 mm long shall be bent to an angle of 90 ° (⁺⁵₀):

- for round conductors, the bending radius shall be equal to 5 times (±1 mm) its diameter;
- for tape conductors, the bending radius shall be equal to 5 times (±1 mm) its thickness.

5.2.3.2 Acceptance criteria

After the test, the specimens shall show no sharp edges, cracks or peeling when inspected with normal or corrected vision without magnification.

5.2.4 Environmental test

5.2.4.1 General conditions for tests

The specimens used in and complying with 5.2.3, air termination rods, earth lead-in rods, down conductors and earth conductors, shall be subjected to an environmental test as specified in A.1, followed by a humid sulphurous atmosphere test as specified in A.2.

5.2.4.2 Acceptance criteria

After the tests, the base metal of the specimens shall not exhibit any visual corrosive deterioration when inspected with normal or corrected vision without magnification.

5.2.5 Tensile tests

5.2.5.1 General conditions for tests

For the methodology of carrying out tensile strength (R_m), see ISO 6892-1. For the testing of air termination rods and earth lead-in rods, the test specimens should be tested un-machined as per D.1 of ISO 6892-1:2009.

5.2.5.2 Acceptance criteria

The specimens are deemed to have passed the tests if they comply with the requirements of Table 2 and Table 4 for the earth conductors.

5.2.6 Electrical resistivity test

5.2.6.1 General conditions for tests

A sample length of conductor, approximately 1,2 m long should be used for the test. The resistance measurement should be taken over a 1 m (± 1 mm) distance, using a micro-ohmmeter, and the reading corrected to 20 °C using appropriate correction factors.

The sample shall be weighed.

The resistivity of the sample length of conductor can then be found by the formula:

$$\text{Resistivity} \quad \rho = \frac{R \times a}{\ell} (\Omega\text{m})$$

where

R is the resistance in Ω over 1 m length;

a is the cross sectional area (m^2);

ℓ is the unit length (m).

See Annex D for a typical example calculation.

The dimensions of the conductor should be measured at three equally distributed points along 1 m length and its cross sectional area should be within a (± 5 %) tolerance.

5.2.6.2 Acceptance criteria

The specimens are deemed to have passed the tests if they comply with the requirements of Table 2 and Table 4.

5.3 Earth rods

5.3.1 General

Copper coated steel earth rods shall be subjected to the tests according to 5.3. Other earth rods shall be subjected to the test according to 5.3, except the test of 5.3.3 and 5.3.4.

5.3.2 Tests for thickness coating on earth rods

5.3.2.1 General conditions for tests

Specimens each approximately 500 mm long shall be subjected to a test for copper or galvanized coating thickness.

The copper or the zinc coating on a steel cored earth rod should be measured using a magnetic method instrument complying with ISO 2178.

NOTE Zinc coating can also be measured in accordance with ISO 1460 or ISO 1461.

Measurements should be taken at three positions along the length of the rod: one measurement at 50 mm in from the top of the rod, one at 50 mm in from the bottom of the rod and one at the mid-point of the rod.

At each position detailed above, two additional measurements should be taken around the circumference of the rod, separated approximately by 120° (see Key of Figure 1).

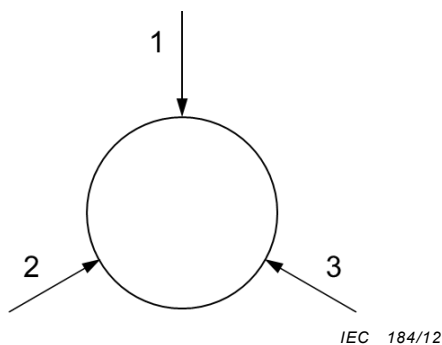

Key

1, 2, 3 measurements

Figure 1 – Coating measurements around the circumference of the rod

5.3.2.2 Acceptance criteria

The specimens are deemed to have passed the tests if they comply with the requirements of Table 3.

Additionally, for the zinc coated earth rods, the coating shall be smooth, continuous and free from flux stains with a minimum weight of 350 g/m².

5.3.3 Adhesion test

5.3.3.1 General conditions for tests

The copper coated steel earth rods specimens used in and complying with 5.3.2, with one end cut to an angle of approximately 45° chamfer, shall be subjected to the following test.

The specimens are driven through two steel clamping plates or the jaws of a vice set $1 \begin{pmatrix} 0,00 \\ -0,25 \end{pmatrix}$ mm less than the diameter of the specimens, so as to shear off sufficient metal to expose the bond between the coating and the parent metal. A test arrangement for the adhesion test is shown in Figure 2.

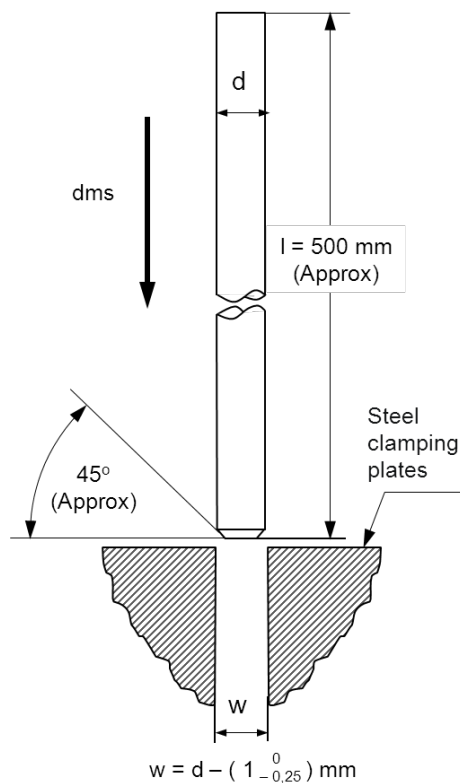

IEC 185/12

Key

dms direction of mechanical stress

Figure 2 – Typical test arrangement for adhesion test

5.3.3.2 Acceptance criteria

After the test, the coating of the specimens shall show adherence to the parent metal. Separation of the copper from the steel is not acceptable.

NOTE Adhesion test for galvanized steel is under consideration.

5.3.4 Bend test

5.3.4.1 General conditions for tests

The copper coated steel earth rods specimens used in and complying with 5.3.3 shall be bent through a radius equal to 5 times (± 1 mm) its diameter to an angle of 90° (± 5 °).

5.3.4.2 Acceptance criteria

After the test, the specimens shall show no sharp edges, cracks or peeling around the bending area when inspected with normal or corrected vision without magnification.

5.3.5 Environmental test

5.3.5.1 General conditions for tests

The copper coated steel earth rods specimens used in and complying with 5.3.4 and the zinc coated earth rods specimens used and complying with 5.3.2 shall be subjected to an environmental test as specified in A.1, followed by a humid sulphurous atmosphere test as specified in A.2.

5.3.5.2 Acceptance criteria

After the test, the specimens shall satisfy the following criteria:

- a) the specimens shall be of good visual appearance and have no rough edges or burrs throughout their length;
- b) the base metal of the specimens shall not exhibit any visual corrosive deterioration when inspected with normal or corrected vision without magnification. 100 mm from both ends of the specimens are excluded from inspection.

NOTE White rust is not considered as corrosive deterioration.

5.3.6 Tensile strength tests

5.3.6.1 General conditions for tests

For the methodology of carrying out tensile strength [R_m] tests, see ISO 6892-1. For the testing of earth rods the test specimen should be tested un-machined as per D.1 of ISO 6892-1:2009.

5.3.6.2 Acceptance criteria

The specimens are deemed to have passed the tests if they comply with the requirements of Table 4.

5.3.7 Test for yield/tensile ratio

5.3.7.1 General conditions for tests

The yield/tensile ratio is determined by ascertaining the upper yield strength [R_{eH}] and dividing the result by the tensile strength [R_m] (see Figure 3).

5.3.7.2 Acceptance criteria

The specimens are deemed to have passed the tests if they comply with the requirements of Table 4.

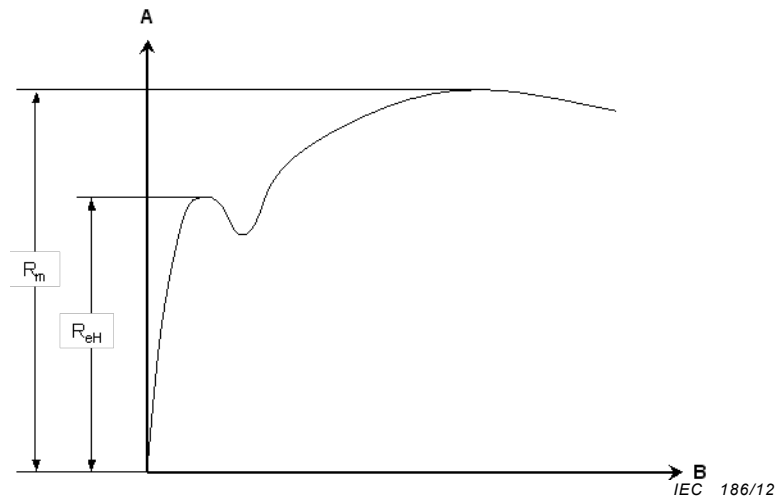

Key

- A tensile strength
- B elongation

Figure 3 – Definitions of upper yield strength R_{eH} (Mpa) and tensile strength R_m (Mpa)

5.3.8 Electrical resistivity test

5.3.8.1 General conditions for tests

A sample length of earth rod, approximately 1,2 m long, should be used for the test. The resistance measurement should be taken over a 1 m (± 1 mm) distance, using a micro-ohmmeter, and the reading corrected to 20 °C, using appropriate correction factors.

The sample shall be weighed.

The resistivity of the sample length of the earth rod can then be calculated using the formula:

resistivity
$$\rho = \frac{R \times a}{\ell} (\mu\Omega m)$$

where

- R is the resistance in micro-ohms ($\mu\Omega$) over a 1 m length;
- a is the cross sectional area (m^2);
- ℓ is the unit length (m).

See Annex D for a typical example calculation.

The dimensions of the earth rod should be measured at three equally distributed points along 1 m length and its cross sectional area should be within a (± 5 %) tolerance.

5.3.8.2 Acceptance criteria

The specimens are deemed to have passed the tests if they comply with the requirements of Table 4.

5.4 Joints for earth rods

5.4.1 General

Joints for earth rods shall be subjected to the following tests to confirm their suitability for the intended application.

5.4.2 Compression tests by mechanical means

5.4.2.1 General conditions for tests

Each specimen shall be assembled from two parts of rods each 500 mm long. The tests shall be performed with suitable driving heads and driving tools following the manufacturer's or supplier's instructions.

The top of the specimens shall be impacted with a vibration hammer defined with the following parameters, for a duration of 2 min:

- percussion rate $(2\ 000 \pm 1\ 000)\ \text{min}^{-1}$;
- single stroke impact energy $(50 \pm 10)\ \text{Nm}$.

A typical test arrangement is shown in Figure 4.

Dimensions in millimetres

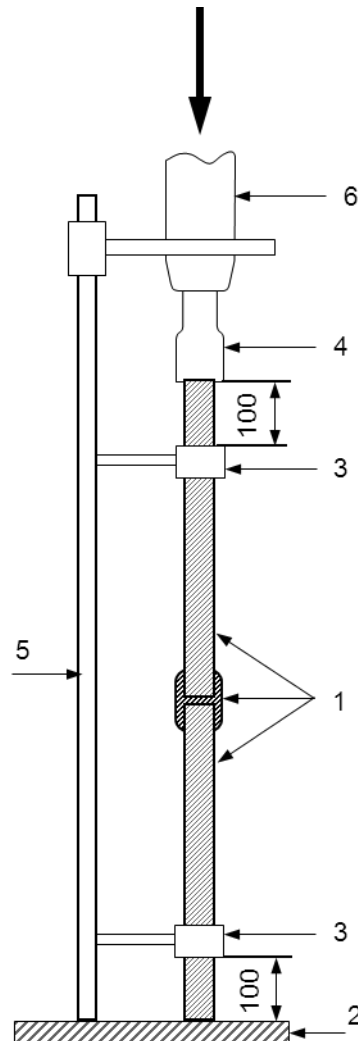

IEC 187/12

Key

- 1 specimen
- 2 metal plate
- 3 bearing
- 4 driving head
- 5 test holder
- 6 vibration hammer

Figure 4 – Typical test arrangement for the compression test by mechanical means

5.4.2.2 Acceptance criteria

The specimens are deemed to have passed the tests if their joints are not broken or do not show any crack to normal or corrected vision without magnification.

5.4.3 Environmental – Electrical tests

5.4.3.1 General conditions for tests

Specimen assemblies used in and complying with 5.4.2 shall be subjected to an environmental test consisting of a salt mist test as specified in A.1, followed by a humid sulphurous atmosphere test as specified in A.2, and an additional ammonia atmosphere

treatment as described in A.3 for specimens made of copper alloy with a copper content less than 80 %.

After the conditioning test and without cleaning, the assembly shall be subjected to an electrical test as per 6.3 of IEC 62561-1:-. Finally, the specimen assemblies shall then be subjected to a mechanical tensile force of 1 000 N (± 10 N).

5.4.3.2 Acceptance criteria

The specimens are deemed to have passed the tests if:

- a) the joints are not broken or do not show any crack to normal or corrected vision without magnification;
- b) the contact resistance measured with a source of at least 10 A, as close as possible to the joint, is equal or less than 1 m Ω , but in the case of stainless steel equal or less than 2,5 m Ω ;
- c) the specimen assembly still remains intact.

5.5 Marking test

5.5.1 General conditions for tests

The marking is checked by inspection and by rubbing it by hand for 15 s with a piece of cloth soaked with water and again for 15 s with a piece of cloth soaked with white spirit/mineral spirit.

Marking made by moulding, pressing or engraving is not subjected to this test.

5.5.2 Acceptance criteria

After the test, the marking shall be legible.

6 Electromagnetic compatibility (EMC)

Products covered by this standard are, in normal use, passive in respect of electromagnetic influences (emission and immunity).

7 Structure and content of the test report

7.1 General

The purpose of this clause is to provide general requirements for laboratory test reports. It is intended to promote clear, complete reporting procedures for laboratories submitting test reports.

The results of each test carried out by the laboratory shall be reported accurately, clearly, unambiguously and objectively, in accordance with any instructions in the test methods. The results shall be reported in a test report and shall include all the information necessary for the interpretation of the test results and all information required by the method used.

Particular care and attention shall be paid to the arrangement of the report, especially with regard to presentation of the test data and ease of assimilation by the reader. The format shall be carefully and specifically designed for each type of test carried out, but the headings shall be standardized as indicated below.

The structure of each report shall include at least the following information contained in 7.2 to 7.10.

7.2 Report identification

- a) A title or subject of the report;
- b) Name, address, e-mail and telephone number of the test laboratory;
- c) Name, address, e-mail and telephone number of the sub test laboratory where the test was carried out if different from company which has been assigned to perform the test;
- d) Unique identification number (or serial number) of the test report;
- e) Name and address of the vendor;
- f) Report shall be paginated and the total number of pages indicated;
- g) Date of issue of report;
- h) Date(s) of performance of test(s);
- i) Signature and title, or an equivalent identification of the person(s) authorized to sign for the testing laboratory for the content of the report;
- j) Signature and title of person(s) conducting the test.

7.3 Specimen description

- a) Sample description;
- b) Detailed description and unambiguous identification of the test sample and/or test assembly;
- c) Characterization and condition of the test sample and/or test assembly;
- d) Sampling procedure, where relevant;
- e) Date of receipt of test items;
- f) Photographs, drawings or any other visual documentation, if available.

7.4 Conductor

- a) Conductor material;
- b) Cross-section area, dimensions and shape. It is recommended that the actual cross-sectional area should also be given.

7.5 Standards and references

- a) Identification of the test standard used and the date of issue of the standard;
- b) Other relevant documentation with the documentation date.

7.6 Test procedure

- a) Description of the test procedure;
- b) Justification for any deviations from, additions to or exclusions from the referenced standard;
- c) Any other information relevant to a specific test such as environmental conditions;
- d) Configuration of testing assembly;
- e) Location of the arrangement in the testing area and measuring techniques.

7.7 Testing equipment, description

Description of equipment used for every test conducted, i.e. generator, conditioning/ ageing device.

7.8 Measuring instruments description

Characteristics and calibration date of all instruments used for measuring the values specified in the standard, i.e. radius gauge shunts, tensile testing machine, extensometer, ohmmeter, torque meter, thickness caliper gauge, etc.

7.9 Results and parameters recorded

- a) The required passing criteria for each test, defined by the standard;
- b) The relevant observed or derived results of the tests.

All results shall be presented in tables, graphs, drawings, photographs or other documentation of visual observations as appropriate.

7.10 Statement of pass/fail

A statement of pass/fail identifying the part of the test for which the specimen has failed and also a description of the failure.

Annex A (normative)

Environmental test for conductors, air termination rods and earth lead-in rods

A.1 Salt mist test

The salt mist test shall be in accordance with IEC 60068-2-52:1996, except for Clauses 7, 10 and 11 which are not applicable. The test is carried out using severity (2).

If the salt mist chamber can maintain the temperature conditions as specified in 9.3 of IEC 60068-2-52:1996 and a relative humidity of not less than 90 %, then the specimen may remain in it for the humidity storage period.

A.2 Humid sulphurous atmosphere test

The humid sulphurous atmosphere treatment shall be in accordance with ISO 6988:1985 with seven cycles with a concentration of sulphur dioxide of 667×10^{-6} (in volume) $\pm 25 \times 10^{-6}$, except for Clauses 9 and 10 which are not applicable.

Each cycle which has duration of 24 h is composed of a heating period of 8 h at a temperature of $40 \text{ }^{\circ}\text{C} \pm 3 \text{ }^{\circ}\text{C}$ in the humid saturated atmosphere which is followed by a rest period of 16 h. After that, the humid sulphurous atmosphere is replaced.

If the test chamber maintains the temperature conditions as specified in 6.5.2 of ISO 6988:1985 then the specimen may remain in it for the storage period.

A.3 Ammonia atmosphere treatment

The ammonia atmosphere treatment shall be in accordance with ISO 6957:1988 for a moderate atmosphere with the pH value 10 except for 8.4 and Clause 9, which are not applicable.

Annex B (normative)

Requirements for the cross sectional area, mechanical and electrical characteristics, tests to be applied

The following is a summary of requirements for cross sectional area, mechanical and electrical characteristics as well as tests to be applied for air termination conductors, air termination rods, earth lead-in rods and down conductors according to Table 1 and Table 2.

**Table B.1 – Summary of requirements for various elements tested
according to Table 1 and Table 2**

Material	Configuration	Cross sectional area, mechanical and electrical characteristics, tests to be applied
Copper Tin plated copper	Solid tape Solid round Stranded	Table 1 / Table 2 Tests: Footnotes of Table 1, 5.2.4 / 5.2.5 / 5.2.6
Aluminium	Solid tape Solid round Stranded	Table 1 / Table 2 Tests: Footnotes of Table 1, 5.2.4 / 5.2.5 / 5.2.6
Copper coated aluminium alloy	Solid round	Table 1 / Table 2 Tests: Footnotes of Table 1, 5.2.2 / 5.2.3 / 5.2.4 / 5.2.5 / 5.2.6
Aluminium alloy	Solid tape Solid round Stranded	Table 1 / Table 2 Tests: NOTE of Table 1, 5.2.4 / 5.2.5 / 5.2.6
Hot dipped galvanized steel	Solid tape Solid round Stranded	Table 1 / Table 2 Tests: Footnotes of Table 1, 5.2.2 / 5.2.3 / 5.2.4 / 5.2.5 / 5.2.6
Copper coated steel	Solid round Solid tape	Table 1 / Table 2 Tests: Footnotes of Table 1, 5.2.2 / 5.2.3 / 5.2.4 / 5.2.5 / 5.2.6
Stainless steel	Solid tape Solid round Stranded	Table 1 / Table 2 Tests: Footnotes of Table 1, 5.2.4 / 5.2.5 / 5.2.6

Annex C
(normative)

Requirements for dimensions, mechanical and electrical characteristics, tests to be applied

The following is a summary of requirements for dimensions, mechanical and electrical characteristics as well as tests to be applied for earth electrodes according to Table 3 and Table 4.

Table C.1 – Summary of requirements for various elements tested according to Table 3 and Table 4

Material	Configuration	Application	Dimensions, mechanical electrical characteristics, tests to be applied
Copper	Solid round Solid round Solid tape Pipe Solid plate Lattice plate Stranded	Earth conductor Earth rod Earth conductor Earth rod Earth plate Earth plate Earth conductor	Table 3 / Table 4 Tests: Footnotes of Table 3 / 5.2.4 / 5.2.5 / 5.2.6
Galvanized steel	Solid round Solid tape Solid plate Lattice plate Stranded	Earth conductor Earth conductor Earth plate Earth plate Earth conductor	Table 3 / Table 4 Tests: Footnotes of Table 3 / 5.2.2 / 5.2.3 / 5.2.4 / 5.2.5 / 5.2.6
Galvanized steel	Solid round Pipe Profile	Earth rod Earth rod Earth rod	Table 3 / Table 4 Tests: Footnotes of Table 3 / 5.3.2 / 5.3.5 / 5.3.6 / 5.3.7 / 5.3.8
Bare steel	Solid round Solid tape	Earth conductor Earth conductor	Table 3 / Table 4 Tests: Footnotes of Table 3 / 5.2.5 / 5.2.6
Copper coated steel	Solid round	Earth rod	Table 3 / Table 4 Tests: Footnotes of Table 3 / 5.3.2 / 5.3.3 / 5.3.4; 5.3.5 / 5.3.6 / 5.3.7 / 5.3.8
Copper coated steel	Solid round Solid tape	Earth conductor Earth conductor	Table 3 / Table 4 Tests: Footnotes of Table 3 / 5.2.2 / 5.2.3 / 5.2.4 / 5.2.5 / 5.2.6
Stainless steel	Solid round Solid round Solid tape	Earth conductor Earth rod Earth conductor	Table 3 / Table 4 Tests: Footnotes of Table 3 / 5.2.4 / 5.2.5 / 5.2.6
Joints for earth rods	-----	-----	Tests: Footnotes of Table 3 / 5.4.2 / 5.4.3. In addition, tests according to 6.3 of IEC 62561-1:-

Annex D (informative)

Typical example calculation of conductor resistivity

As an example, it is assumed that the measured resistance of 1 m of copper conductor corrected to 20 °C is:

$$R = 234 \mu\Omega$$

The measured mass of the 1,2 m length of test sample is taken as:

$$m = 772 \text{ g}$$

Therefore the mass of 1 m of this conductor is:

$$m^* = \frac{772 \text{ g}}{1,2 \text{ m}} = 643 \text{ g/m}$$

The specific density of copper is:

$$\gamma = 0,0089 \text{ g/mm}^3$$

Therefore the calculated cross-sectional area is:

$$\frac{643 \text{ g/m}}{0,0089 \text{ g/mm}^3} = 72,2 \text{ mm}^2$$

Therefore the resistivity is:

$$\rho = \frac{(234 \times 10^6 \times 72,2 \times 10^6)}{1} = 0,0169 \mu\Omega \text{ m}$$

Annex E (informative)

Typical example of calculation of the tensile strength of a coated material

Copper coated solid round rod with:

- overall diameter: 14,2 mm
- radial copper coating thickness: 250 μm = 0,25 mm
- diameter of steel core: 14,2 mm – 0,5 mm = 13,7 mm

Therefore the cross-sectional area (a) is:

$$a = \pi \times r^2 = \pi \times 6,85^2 = 147,43 \text{ mm}^2$$

Ultimate tensile strength (UTS) of copper coated earth rod (complete with copper coating) is:

$$\text{UTS} = 88,458 \text{ kN}$$

The contribution the copper coating makes to the UTS is insignificant and so can be ignored.

Therefore the tensile strength in N/mm^2 is:

$$\frac{\text{UTS}}{a} = \frac{88,458 \times 10^3 \text{ N}}{147,43 \text{ mm}^2} = 600 \text{ N/mm}^2$$

Annex F (normative)

Flow chart of tests for air termination conductors, air termination rods, earth lead-in rods and down conductors

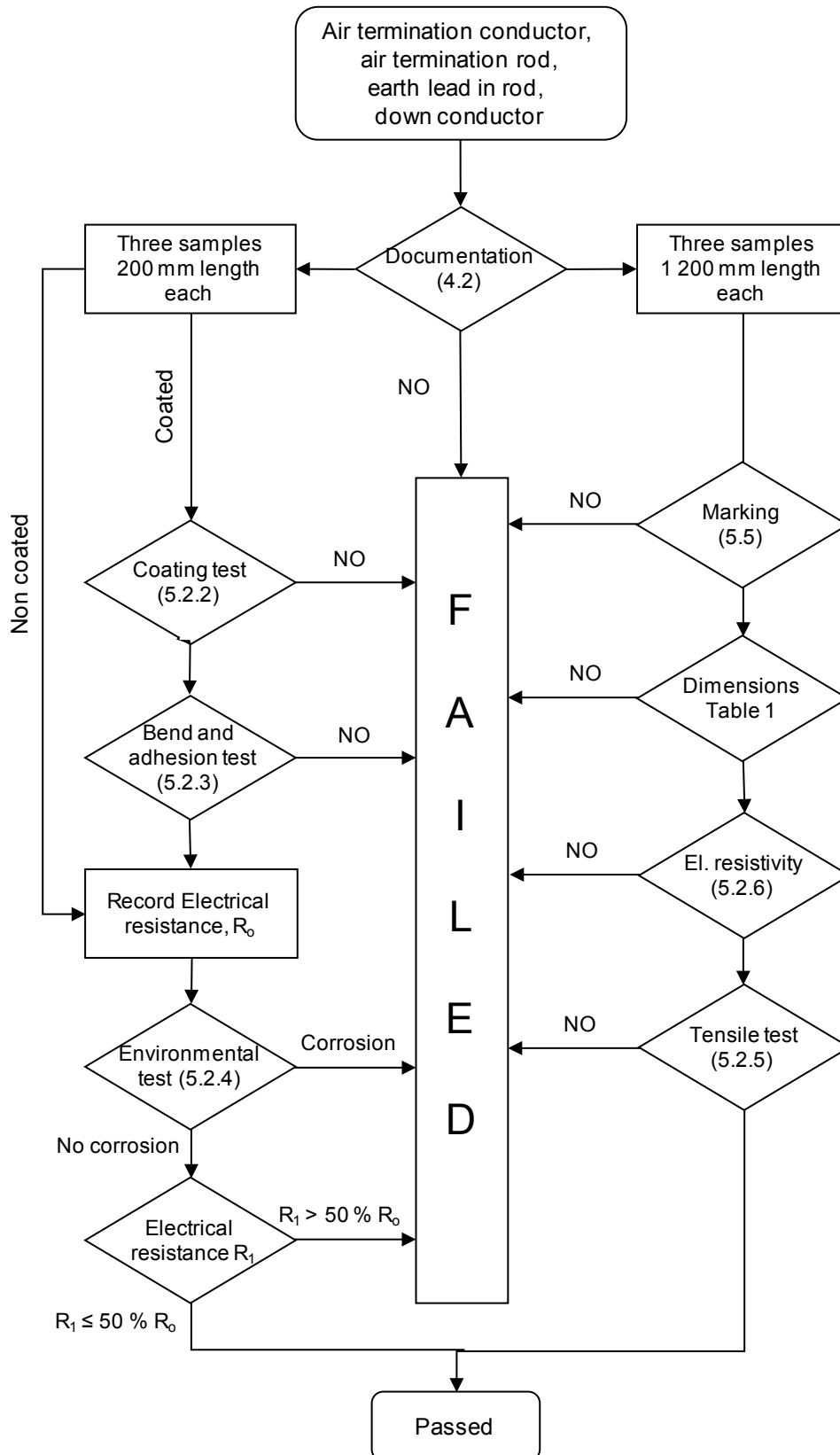

Annex G (normative)

Flow chart of tests for earth rods

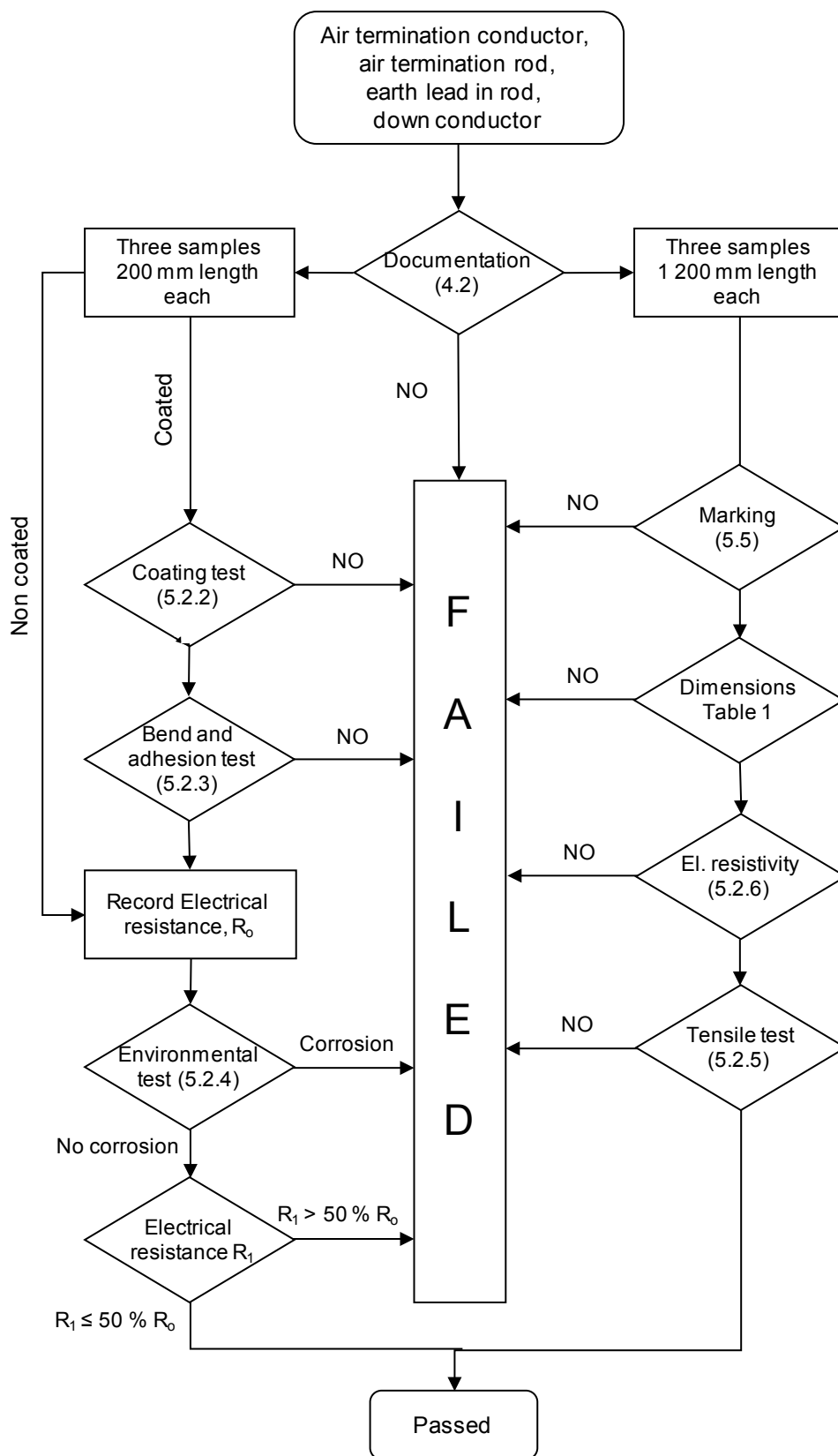

Annex H (normative)

Flow chart of tests of joints for earth rods

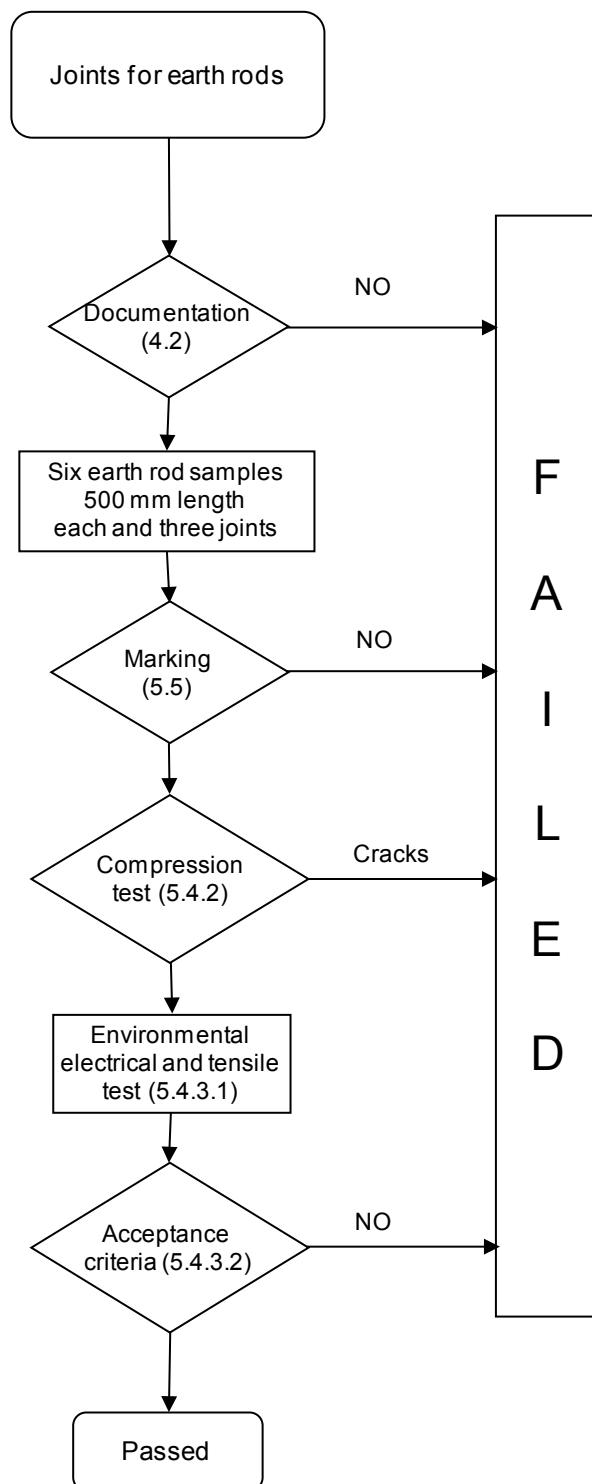

Bibliography

IEC 60050 (all parts), *International Electrotechnical Vocabulary* (available at <http://www.electropedia.org>)

IEC 60228, *Conductors of insulated cables*

IEC 60468:1974, *Method of measurement of resistivity of metallic materials*

IEC 62305-1, *Protection against lightning – Part 1: General principles*

INTERNATIONAL
ELECTROTECHNICAL
COMMISSION

3, rue de Varembé
PO Box 131
CH-1211 Geneva 20
Switzerland

Tel: + 41 22 919 02 11
Fax: + 41 22 919 03 00
info@iec.ch
www.iec.ch