



81/262/FDIS

FINAL DRAFT INTERNATIONAL STANDARD PROJET FINAL DE NORME INTERNATIONALE

Project number IEC 62305-1 Ed. 1.0 Numéro de projet			
IEC/TC or SC CEI/CE ou SC 81	Secretariat / Secrétariat Italy		
<input checked="" type="checkbox"/> Submitted for parallel voting in CENELEC Soumis au vote parallèle au CENELEC	Distributed on / Diffusé le 2005-08-19	Voting terminates on / Vote clos le 2005-10-21	
Also of interest to the following committees Intéresse également les comités suivants 37A, 64, 77		Supersedes document Remplace le document 81/216/CDV - 81/237A/RVC	
Functions concerned Fonctions concernées			
<input type="checkbox"/> Safety Sécurité	<input type="checkbox"/> EMC CEM	<input type="checkbox"/> Environment Environnement	<input type="checkbox"/> Quality assurance Assurance de la qualité

INTERNATIONAL ELECTROTECHNICAL COMMISSION

COMMISSION ÉLECTROTECHNIQUE INTERNATIONALE

THIS DOCUMENT IS A DRAFT DISTRIBUTED FOR APPROVAL. IT MAY NOT BE REFERRED TO AS AN INTERNATIONAL STANDARD UNTIL PUBLISHED AS SUCH.

IN ADDITION TO THEIR EVALUATION AS BEING ACCEPTABLE FOR INDUSTRIAL, TECHNOLOGICAL, COMMERCIAL AND USER PURPOSES, FINAL DRAFT INTERNATIONAL STANDARDS MAY ON OCCASION HAVE TO BE CONSIDERED IN THE LIGHT OF THEIR POTENTIAL TO BECOME STANDARDS TO WHICH REFERENCE MAY BE MADE IN NATIONAL REGULATIONS.

CE DOCUMENT EST UN PROJET DIFFUSÉ POUR APPROBATION. IL NE PEUT ÊTRE CITÉ COMME NORME INTERNATIONALE AVANT SA PUBLICATION EN TANT QUE TELLE.

OUTRE LE FAIT D'ÊTRE EXAMINÉS POUR ÉTABLIR S'ILS SONT ACCEPTABLES À DES FINS INDUSTRIELLES, TECHNOLOGIQUES ET COMMERCIALES, AINSI QUE DU POINT DE VUE DES UTILISATEURS, LES PROJETS FINAUX DE NORMES INTERNATIONALES DOIVENT PARFOIS ÊTRE EXAMINÉS EN VUE DE LEUR POSSIBILITÉ DE DEVENIR DES NORMES POUVANT SERVIR DE RÉFÉRENCE DANS LES RÉGLEMENTATIONS NATIONALES.

Title

IEC 62305-1 Ed. 1.0: Protection against lightning – Part 1: General principles

Titre

CEI 62305-1 Ed. 1.0: Protection contre la foudre – Partie 1: Principes généraux

ATTENTION VOTE PARALLÈLE CEI – CENELEC

L'attention des Comités nationaux de la CEI, membres du CENELEC, est attirée sur le fait que ce projet final de Norme internationale est soumis au vote parallèle. Un bulletin de vote séparé pour le vote CENELEC leur sera envoyé par le Secrétariat Central du CENELEC.

ATTENTION IEC – CENELEC PARALLEL VOTING

The attention of IEC National Committees, members of CENELEC, is drawn to the fact that this final Draft International Standard (DIS) is submitted for parallel voting. A separate form for CENELEC voting will be sent to them by the CENELEC Central Secretariat.

Copyright © 2005 International Electrotechnical Commission, IEC. All rights reserved. It is permitted to download this electronic file, to make a copy and to print out the content for the sole purpose of preparing National Committee positions. You may not copy or "mirror" the file or printed version of the document, or any part of it, for any other purpose without permission in writing from IEC.

1906-2006
The electric century

CONTENTS

FOREWORD.....	5
INTRODUCTION.....	7
1 Scope.....	8
2 Normative references.....	8
3 Terms and definitions	8
4 Lightning current parameters	14
5 Damage due to lightning	14
5.1 Damage to a structure	14
5.2 Damage to a service.....	17
5.3 Types of loss	18
6 Need and economic convenience for lightning protection.....	20
6.1 Need for lightning protection	20
6.2 Economic convenience of lightning protection	21
7 Protection measures	21
7.1 Protection measures to reduce injury of living beings due to touch and step voltages.....	21
7.2 Protection measures to reduce physical damage.....	21
7.3 Protection measures to reduce failure of electrical and electronic systems	22
7.4 Protection measures selection	22
8 Basic criteria for protection of structures and services.....	22
8.1 Lightning protection levels (LPL).....	23
8.2 Lightning protection zones (LPZ).....	27
8.3 Protection of structures.....	28
8.4 Protection of services	29
Annex A (informative) Parameters of lightning current	30
Annex B (informative) Time functions of the lightning current for analysis purposes	38
Annex C (informative) Simulation of the lightning current for test purposes	44
Annex D (informative) Test parameters simulating the effects of lightning on LPS components	48
Annex E (informative) Surges due to lightning at different installation points	63
Bibliography.....	68

Figure 1 – Types of loss resulting from different types of damage	20
Figure 2 – LPZ defined by an LPS (IEC 62305-3).....	25
Figure 3 – LPZ defined by protection measures against LEMP (IEC 62305-4)	26
Figure A.1 – Definitions of short stroke parameters (typically $T_2 < 2$ ms).....	30
Figure A.2 – Definitions of long stroke parameters (typically $2 \text{ ms} < T_{\text{long}} < 1 \text{ s}$).....	31
Figure A.4 – Possible components of upward flashes (typical to exposed and/or higher structures)	32
Figure A.5 – Cumulative frequency distribution of lightning current parameters (lines through 95 % and 5 % value).....	35
Figure B.1 – Waveshape of the current rise of the first short stroke	39
Figure B.2 – Waveshape of the current tail of the first short stroke	40
Figure B.3 – Waveshape of the current rise of the subsequent short strokes.....	41
Figure B.4 – Waveshape of the current tail of the subsequent short strokes	42
Figure B.5 – Amplitude density of the lightning current according to LPL I	43
Figure C.1 – Example test generator for the simulation of the specific energy of the first short stroke and the charge of the long stroke	45
Figure C.2 – Definition for the current steepness in accordance with Table C.3.....	46
Figure C.3 – Example test generator for the simulation of the front steepness of the first short stroke for large test items	47
Figure C.4 – Example test generator for the simulation of the front steepness of the subsequent short strokes for large test items.....	47
Figure D.1 – General arrangement of two conductors for the calculation of electrodynamic force	55
Figure D.2 – Typical conductor arrangement in an LPS.....	55
Figure D.3 – Diagram of the stresses for the configuration of Figure D.2.....	56
Figure D.4 – Force per unit length along the horizontal conductor of Figure D.2	56
Table 1 – Effects of lightning on typical structures	15
Table 2 – Effects of lightning on typical services	17
Table 3 – Damages and loss in a structure according to different points of strike of lightning	19
Table 4 – Damages and loss in a service according to different points of strike of lightning	19
Table 5 – Maximum values of lightning parameters according to LPL	24
Table 6 – Minimum values of lightning parameters and related rolling sphere radius corresponding to LPL	27
Table 7 – Probabilities for the limits of the lightning current parameters	27
Table A.1 – Tabulated values of lightning current parameters taken from CIGRE (Electra No. 41 or No. 69*) ^{[3], [4]}	33
Table A.2 – Logarithmic normal distribution of lightning current parameters – Mean μ and dispersion σ_{\log} calculated from 95 % and 5 % values from CIGRE (Electra No 41 or No 69) ^{[3], [4]}	34

Table B.1 – Parameters for Equation B.1 38

Table C.1 – Test parameters of the first short stroke 45

Table C.2 – Test parameters of the long stroke 45

Table C.3 – Test parameters of the short strokes 46

Table D.1 – Summary of the lightning threat parameters to be considered in the calculation of the test values for the different LPS components and for the different LPL..... 49

Table D.2 – Physical characteristics of typical materials used in LPS components 52

Table D.3 – Temperature rise for conductors of different sections as a function of W/R 52

Table E.1 – Conventional earthing impedance values Z and Z_1 according to the resistivity of the soil..... 64

Table E.2 – Expected surge overcurrents due to lightning flashes 65

INTERNATIONAL ELECTROTECHNICAL COMMISSION

PROTECTION AGAINST LIGHTNING –

Part 1: General principles

FOREWORD

- 1) The International Electrotechnical Commission (IEC) is a worldwide organization for standardization comprising all national electrotechnical committees (IEC National Committees). The object of IEC is to promote international co-operation on all questions concerning standardization in the electrical and electronic fields. To this end and in addition to other activities, IEC publishes International Standards, Technical Specifications, Technical Reports, Publicly Available Specifications (PAS) and Guides (hereafter referred to as “IEC Publication(s)”). Their preparation is entrusted to technical committees; any IEC National Committee interested in the subject dealt with may participate in this preparatory work. International, governmental and non-governmental organizations liaising with the IEC also participate in this preparation. IEC collaborates closely with the International Organization for Standardization (ISO) in accordance with conditions determined by agreement between the two organizations.
- 2) The formal decisions or agreements of IEC on technical matters express, as nearly as possible, an international consensus of opinion on the relevant subjects since each technical committee has representation from all interested IEC National Committees.
- 3) IEC Publications have the form of recommendations for international use and are accepted by IEC National Committees in that sense. While all reasonable efforts are made to ensure that the technical content of IEC Publications is accurate, IEC cannot be held responsible for the way in which they are used or for any misinterpretation by any end user.
- 4) In order to promote international uniformity, IEC National Committees undertake to apply IEC Publications transparently to the maximum extent possible in their national and regional publications. Any divergence between any IEC Publication and the corresponding national or regional publication shall be clearly indicated in the latter.
- 5) IEC provides no marking procedure to indicate its approval and cannot be rendered responsible for any equipment declared to be in conformity with an IEC Publication.
- 6) All users should ensure that they have the latest edition of this publication.
- 7) No liability shall attach to IEC or its directors, employees, servants or agents including individual experts and members of its technical committees and IEC National Committees for any personal injury, property damage or other damage of any nature whatsoever, whether direct or indirect, or for costs (including legal fees) and expenses arising out of the publication, use of, or reliance upon, this IEC Publication or any other IEC Publications.
- 8) Attention is drawn to the Normative references cited in this publication. Use of the referenced publications is indispensable for the correct application of this publication.
- 9) Attention is drawn to the possibility that some of the elements of this IEC Publication may be the subject of patent rights. IEC shall not be held responsible for identifying any or all such patent rights.

International Standard IEC 62305-1 has been prepared by IEC technical committee 81: Lightning protection.

The IEC 62305 series (Parts 1 to 5), is produced in accordance with the New Publications Plan, approved by National Committees (81/171/RQ (2001-06-29)), which restructures and updates in a more simple and rational form the publications of the IEC 61024 series, the IEC 61312 series and the IEC 61663 series.

The text of this first edition of IEC 62305-1 is compiled from and replaces

- IEC 61024-1-1, first edition (1993);
- IEC 61024-1-2, first edition (1998).

The text of this standard is based on the following documents:

FDIS	Report on voting
81/XX/FDIS	81/XX/RVD

Full information on the voting for the approval of this standard can be found in the report on voting indicated in the above table.

This publication has been drafted, as close as possible, in accordance with the ISO/IEC Directives, Part 2.

IEC 62305 consists of the following parts, under the general title *Protection against lightning*:

Part 1: General principles

Part 2: Risk management

Part 3: Physical damage to structures and life hazard

Part 4: Electrical and electronic systems within structures

Part 5: Services

The committee has decided that the contents of this publication will remain unchanged until the maintenance result date¹ indicated on the IEC web site under "<http://webstore.iec.ch>" in the data related to the specific publication. At this date, the publication will be

- reconfirmed;
- withdrawn;
- replaced by a revised edition, or
- amended.

¹ The National Committees are requested to note that for this publication the maintenance result date is 2010.

INTRODUCTION

There are no devices nor methods capable of modifying the natural weather phenomena to the extent that they can prevent lightning discharges. Lightning flashes to, or nearby, structures (or services connected to the structures) are hazardous to people, to the structures themselves, their contents and installations as well as to services. This is why the application of lightning protection measures is essential.

The need for protection, the economic benefits of installing protection measures and the selection of adequate protection measures should be determined in terms of risk management. Risk management is the subject of IEC 62305-2.

The criteria for design, installation and maintenance of lightning protection measures are considered in three separate groups:

- the first group concerns protection measures to reduce physical damage and life hazard in a structure is given in IEC 62305-3,
- the second group concerns protection measures to reduce failures of electrical and electronic systems in a structure is given in IEC 62305-4,
- the third group concerns protection measures to reduce physical damage and failures of services connected to a structure (mainly electrical and telecommunication lines) is given in IEC 62305-5.

PROTECTION AGAINST LIGHTNING –

Part 1: General principles

1 Scope

This part of IEC 62305 provides the general principles to be followed in the protection against lightning of

- structures including their installations and contents as well as persons,
- services connected to a structure.

The following cases are outside the scope of this standard:

- railway systems;
- vehicles, ships, aircraft, offshore installations;
- underground high pressure pipelines;
- piping, power and telecommunication lines not connected to a structure.

NOTE Usually these systems are under special regulations made by various specific authorities.

2 Normative references

The following referenced documents are indispensable for the application of this document. For dated references, only the edition cited applies. For undated references, the latest edition of the referenced document (including any amendments) applies.

IEC 62305-2, *Protection against lightning – Part 2: Risk management*

IEC 62305-3, *Protection against lightning – Part 3: Physical damage to structures and life hazard*

IEC 62305-4, *Protection against lightning – Part 4: Electrical and electronic systems within structures*

IEC 62305-5, *Protection against lightning – Part 5: Services*

3 Terms and definitions

For the purposes of this document, the following terms and definitions apply.

3.1

lightning flash to earth

electrical discharge of atmospheric origin between cloud and earth consisting of one or more strokes

3.2**downward flash**

lightning flash initiated by a downward leader from cloud to earth

NOTE A downward flash consists of a first short stroke, which can be followed by subsequent short strokes. One or more short strokes may be followed by a long stroke.

3.3**upward flash**

lightning flash initiated by an upward leader from an earthed structure to cloud

NOTE An upward flash consists of a first long stroke with or without multiple superimposed short strokes. One or more short strokes may be followed by a long stroke.

3.4**lightning stroke**

single electrical discharge in a lightning flash to earth

3.5**short stroke**

part of the lightning flash which corresponds to an impulse current

NOTE This current has a time to the half value T_2 typically less than 2 ms (see Figure A.1).

3.6**long stroke**

part of the lightning flash which corresponds to a continuing current

NOTE The duration time T_{long} (time from the 10 % value on the front to the 10 % value on the tail) of this continuing current is typically more than 2 ms and less than 1 s (see Figure A.2)

3.7**multiple strokes**

lightning flash consisting on average of 3-4 strokes, with typical time interval between them of about 50 ms

NOTE Events having up to a few dozen strokes with intervals between them ranging from 10 ms to 250 ms have been reported.

3.8**point of strike**

point where a lightning flash strikes the earth, or protruding object (e.g. structure, LPS, service, tree, etc.)

NOTE A lightning flash may have more than one point of strike.

3.9**lightning current**

i

current flowing at the point of strike

3.10**peak value**

I

maximum value of the lightning current

3.11**average steepness of the front of short stroke current**

average rate of change of current within a time interval $t_2 - t_1$

NOTE It is expressed by the difference $i(t_2) - i(t_1)$ of the values of the current at the start and at the end of this interval, divided by $t_2 - t_1$ (see Figure A.1).

3.12**front time of short stroke current** T_1

virtual parameter defined as 1,25 times the time interval between the instants when the 10 % and 90 % of the peak value are reached (see Figure A.1)

3.13**virtual origin of short stroke current** O_1

point of intersection with time axis of a straight line drawn through the 10 % and the 90 % reference points on the stroke current front (see Figure A.1); it precedes by 0,1 T_1 that instant at which the current attains 10 % of its peak value

3.14**time to half value of short stroke current** T_2

virtual parameter defined as the time interval between the virtual origin O_1 and the instant at which the current has decreased to half the peak value (see Figure A.1)

3.15**flash duration** T

time for which the lightning current flows at the point of strike

3.16**duration of long stroke current** T_{long}

time duration during which the current in a long stroke is between the 10 % of the peak value during the increase of the continuing current and 10 % of the peak value during the decrease of the continuing current (see Figure A.2)

3.17**flash charge** Q_{flash}

time integral of the lightning current for the entire lightning flash duration

3.18**short stroke charge** Q_{short}

time integral of the lightning current in a short stroke

3.19**long stroke charge** Q_{long}

time integral of the lightning current in a long stroke

3.20**specific energy** W/R

time integral of the square of the lightning current for the entire flash duration

NOTE It represents the energy dissipated by the lightning current in a unit resistance.

3.21**specific energy of short stroke current**

time integral of the square of the lightning current for the duration of the short stroke

NOTE The specific energy in a long stroke current is negligible.

3.22**object to be protected**

structure or service to be protected against the effects of lightning

3.23**structure to be protected**

structure for which protection is required against the effects of lightning in accordance with this standard

NOTE A structure to be protected may be a part of a larger structure.

3.24**service to be protected**

service connected to a structure for which protection is required against the effects of lightning in accordance with this standard

3.25**lightning flash to an object**

lightning flash striking an object to be protected

3.26**lightning flash near an object**

lightning flash striking close enough to an object to be protected that it may cause dangerous overvoltages

3.27**electrical system**

system incorporating low voltage power supply components

3.28**electronic system**

system incorporating sensitive electronic components such as communication equipment, computer, control and instrumentation systems, radio systems, power electronic installations

3.29**internal systems**

electrical and electronic systems within a structure

3.30**physical damage**

damage to a structure (or to its contents) or to a service due to mechanical, thermal, chemical and explosive effects of lightning

3.31**injury of living beings**

injuries, including loss of life, to people or to animals due to touch and step voltages caused by lightning

3.32**failure of electrical and electronic systems**

permanent damage of electrical and electronic systems due to LEMP

3.33**lightning electromagnetic impulse**

LEMP

electromagnetic effects of lightning current

NOTE It includes conducted surges as well as radiated impulse electromagnetic field effects.

3.34**surge**

transient wave appearing as overvoltage and /or overcurrent caused by LEMP

NOTE Surges caused by LEMP can arise from (partial) lightning currents, from induction effects in installation loops and as remaining threat downstream of SPD.

3.35**lightning protection zone**

LPZ

zone where the lightning electromagnetic environment is defined

NOTE The zone boundaries of an LPZ are not necessarily physical boundaries (e.g. walls, floor and ceiling).

3.36**risk** R

value of probable average annual loss (humans and goods) due to lightning, relative to the total value (humans and goods) of the object to be protected

3.37**tolerable risk** R_T

maximum value of the risk which can be tolerated for the object to be protected

3.38**lightning protection level**

LPL

number related to a set of lightning current parameters values relevant to the probability that the associated maximum and minimum design values will not be exceeded in naturally occurring lightning

NOTE Lightning protection level is used to design protection measures according to the relevant set of lightning current parameters.

3.39**protection measures**

measures to be adopted in the object to be protected to reduce the risk

3.40**lightning protection system**

LPS

complete system used to reduce physical damage due to lightning flashes to a structure

NOTE It consists of both external and internal lightning protection systems.

3.41**external lightning protection system**

part of the LPS consisting of an air-termination system, a down-conductor system and an earth-termination system

3.42**internal lightning protection system**

part of the LPS consisting of lightning equipotential bonding and/or electrical insulation of external LPS

3.43**air-termination system**

part of an external LPS using metallic elements such as rods, mesh conductors or catenary wires intended to intercept lightning flashes

3.44**down-conductor system**

part of an external LPS intended to conduct lightning current from the air-termination system to the earth-termination system

3.45**earth-termination system**

part of an external LPS which is intended to conduct and disperse lightning current into the earth

3.46**external conductive parts**

extended metal items entering or leaving the structure to be protected such as pipe works, cable metallic elements, metal ducts, etc. which may carry a part of the lightning current

3.47**lightning equipotential bonding**

bonding to LPS of separated metallic parts, by direct conductive connections or via surge protective devices, to reduce potential differences caused by lightning current

3.48**shielding wire**

metallic wire used to reduce physical damage due to lightning flashes to a service

3.49**LEMP protection measures system**

complete system of protection measures for internal systems against LEMP

3.50**magnetic shield**

closed, metallic, grid-like or continuous screen enveloping the object to be protected, or part of it, used to reduce failures of electrical and electronic systems

3.51**surge protective device**

SPD

device intended to limit transient overvoltages and divert surge currents. It contains at least one non linear component

3.52**coordinated SPD protection**

set of SPD properly selected, coordinated and erected to reduce failures of electrical and electronic systems

3.53 rated impulse withstand voltage

U_w

impulse withstand voltage assigned by the manufacturer to the equipment or to a part of it, characterizing the specified withstand capability of its insulation against overvoltages

NOTE For the purposes of this standard, only withstand voltage between live conductors and earth is considered.
(IEC 60664-1:2002) ^{[1]2}

3.54 conventional earthing impedance

ratio of the peak values of the earth-termination voltage and the earth-termination current which, in general, do not occur simultaneously

4 Lightning current parameters

The lightning current parameters used in the IEC 62305 series are given in Annex A.

The time function of the lightning current to be used for analysis purposes is given in Annex B.

Information for simulation of lightning current for test purposes is given in Annex C.

The basic parameters to be used in laboratory to simulate the effects of lightning on LPS components are given in Annex D.

Information on surges due to lightning at different installation points is given in Annex E.

5 Damage due to lightning

5.1 Damage to a structure

Lightning affecting a structure can cause damage to the structure itself and to its occupants and contents, including failure of internal systems. The damages and failures may also extend to the surroundings of the structure and even involve the local environment. The scale of this extension depends on the characteristics of the structure and on the characteristics of the lightning flash.

5.1.1 Effects of lightning on a structure

The main characteristics of structures relevant to lightning effects include:

- construction (e.g. wood, brick, concrete, reinforced concrete, steel frame construction);
- function (dwelling house, office, farm, theatre, hotel, school, hospital, museum, church, prison, department store, bank, factory, industry plant, sports area);
- occupants and contents (persons and animals, presence of combustible or non-combustible materials, explosive or non-explosive materials, electrical and electronic systems with low or high withstand voltage);
- connected services (power lines, telecommunication lines, pipelines);
- existing or provided protection measures (e.g. protection measures to reduce physical damage and life hazard, protection measures to reduce failure of internal systems);

² References in square brackets refer to the bibliography.

- scale of the extension of danger (structure with difficulty of evacuation or structure where panic may be created, structure dangerous to the surroundings, structure dangerous to the environment).

Table 1 reports the effects of lightning on various types of structures.

Table 1 – Effects of lightning on typical structures

Type of structure according to function and/or contents	Effects of lightning
Dwelling-house	Puncture of electrical installations, fire and material damage Damage normally limited to objects exposed to the point of strike or to the lightning current path Failure of electrical and electronic equipment and systems installed (e.g. TV sets, computers, modems, telephones, etc.)
Farm building	Primary risk of fire and hazardous step voltages as well as material damage Secondary risk due to loss of electric power, and life hazard to livestock due to failure of electronic control of ventilation and food supply systems, etc.
Theatre, Hotel, School Department store Sports area	Damage to the electrical installations (e.g. electric lighting) likely to cause panic Failure of fire alarms resulting in delayed fire fighting measures
Bank Insurance company Commercial company, etc.	As above, plus problems resulting from loss of communication, failure of computers and loss of data
Hospital Nursing home Prison	As above, plus problems of people in intensive care, and the difficulties of rescuing immobile people
Industry	Additional effects depending on the contents of factories, ranging from minor to unacceptable damage and loss of production
Museums and archeological sites Church	Loss of irreplaceable cultural heritage
Telecommunications Power plants	Unacceptable loss of services to the public
Firework factory Munition works	Consequences of fire and explosion to the plant and its surroundings
Chemical plant Refinery Nuclear plant Biochemical laboratories and plants	Fire and malfunction of the plant with detrimental consequences to the local and global environment

5.1.2 Sources and types of damage to a structure

The lightning current is the source of damage. The following situations shall be taken into account, depending on the position of the point of strike relative to the structure considered:

- S1: flashes to the structure;
- S2: flashes near the structure;
- S3: flashes to the services connected to the structure;
- S4: flashes near the services connected to the structure.

Flashes to the structure can cause:

- immediate mechanical damage, fire and/or explosion due to the hot lightning plasma arc itself, due to the current resulting in ohmic heating of conductors (over-heated conductors), or due to the charge resulting in arc erosion (melted metal);
- fire and/or explosion triggered by sparks caused by overvoltages resulting from resistive and inductive coupling and to passage of part of the lightning currents;
- injury to people by step and touch voltages resulting from resistive and inductive coupling;
- failure or malfunction of internal systems due to LEMP.

Flashes near the structure can cause:

- failure or malfunction of internal systems due to LEMP.

Flashes to a service connected to the structure can cause:

- fire and/or explosion triggered by sparks due to overvoltages and lightning currents transmitted through the connected service;
- injury to people due to touch voltages inside the structure caused by lightning currents transmitted through the connected service;
- failure or malfunction of internal systems due to overvoltages appearing on connected lines and transmitted to the structure.

Flashes near a service connected to the structure can cause:

- failure or malfunction of internal systems due to overvoltages induced on connected lines and transmitted to the structure.

NOTE 1 Malfunctioning of internal systems is not covered by the IEC 62305 series. Reference should be made to IEC 61000-4-5 ^[2].

NOTE 2 Only the sparks carrying lightning current (total or partial) are regarded as able to trigger fire.

NOTE 3 Lightning flashes, direct to or near the incoming pipelines, do not cause damages to the structure, provided that they are bonded to the equipotential bar of the structure (see IEC 62305-3).

As result, the lightning can cause three basic type of damages:

- D1: injury of living beings due to touch and step voltages;
- D2: physical damage (fire, explosion, mechanical destruction, chemical release) due to lightning current effects including sparking;
- D3: failure of internal systems due to LEMP.

5.2 Damage to a service

Lightning affecting a service can cause damage to the physical means itself (line or pipe) used to provide the service, as well as to connected electrical and electronic equipment.

NOTE The service to be considered is the physical connection between

- the switch telecommunication building and the user's building or two switch telecommunication buildings or two users' buildings, for the telecommunication (TLC) lines,
- the switch telecommunication building or the user's building and a distribution node, or two distribution nodes for the telecommunication (TLC) lines,
- the high voltage (HV) substation and the user's building, for the power lines,
- the main distribution station and the user's building, for pipes.

The scale of this extension depends on the characteristics of the service, on the type and extension of the electrical and electronic systems and on the characteristics of the lightning flash.

5.2.1 Effects of lightning on a service

The main characteristics of services relevant to lightning effects include:

- construction (line: overhead, underground, screened, unscreened, fibre optic; pipe: above ground, buried, metallic, plastic);
- function (telecommunication line, power line, pipeline);
- structure supplied (construction, contents, dimensions, localization);
- existing or provided protection measures (e.g. shielding wire, SPD, route redundancy, fluid storage systems, generating sets, uninterruptible power systems).

Table 2 reports the effects of lightning on various types of services.

Table 2 – Effects of lightning on typical services

Type of service	Effects of lightning
Telecommunication line	Mechanical damage to line, melting of screens and conductors, breakdown of insulation of cable and equipment leading to a primary failure with immediate loss of service Secondary failures on the optical fibre cables with damage of the cable but without loss of service
Power lines	Damages to insulators of low voltage overhead line, puncturing of insulation of cable line, breakdown of insulation of line equipment and of transformers, with consequential loss of service
Water pipes	Damages to electrical and electronic control equipments likely to cause loss of service
Gas pipes Fuel pipes	Puncturing of non-metallic flange gaskets likely to cause fire and/or explosion. Damage to electrical and electronic control equipments likely to cause loss of service

5.2.2 Sources and types of damage to a service

The lightning current is the source of damage. The following situations shall be taken into account, depending on the position of the point of strike relative to the service considered:

- S1: flashes to the supplied structure;
- S3: flashes to the service connected to the structure;
- S4: flashes near the service connected to the structure.

Flashes to the supplied structure can cause:

- melting of metallic wires and of cable screens due to parts of the lightning current flowing into the services (resulting from resistive heating);
- breakdown of insulation of lines and of the connected equipments (due to the resistive coupling);
- puncturing of non-metallic gaskets in flanges of pipes, as well as gaskets in insulating joints.

NOTE 1 Optical fibre cable without metallic conductor are not affected by lightning flashes striking the supplied structure.

Flashes to a service connected to the structure can cause:

- immediate mechanical damage of metallic wires or piping due to electrodynamic stress or heating effects caused by lightning current (breaking and/or melting of metallic wires, screens or piping), and due to the heat of the lightning plasma arc itself (puncturing of plastic protective cover);
- immediate electrical damage of lines (breakdown of insulation) and of connected equipment;
- puncturing of thin overhead metallic pipes and of non-metallic gaskets in flanges, where consequences may extend to fire and explosion depending on the nature of conveyed fluids.

Flashes near a service connected to the structure can cause:

- breakdown of insulation of lines and of the connected equipments due to inductive coupling (induced overvoltages).

NOTE 2 Optical fibre cable without metallic conductors are not affected by lightning flashes striking the ground.

As result, the lightning can cause two basic type of damage:

- D2: physical damage (fire, explosion, mechanical destruction, chemical release) due to thermal effects of lightning current
- D3: failure of electrical and electronic systems due to overvoltages.

5.3 Types of loss

Each type of damage, alone or in combination with others, may produce different consequential loss in the object to be protected. The type of loss that may appear depends on the characteristics of the object itself.

For the purposes of this standard the following types of loss are considered:

- L1: loss of human life;
- L2: loss of service to the public;
- L3: loss of cultural heritage;
- L4: loss of economical value (structure and its content, service and loss of activity).

Loss of type L1, L2 and L3 may be considered as loss of social values, whereas loss of type L4 may be considered as purely economical loss.

Losses which may appear in a structure are as follows:

- L1: loss of human life;
- L2: loss of service to the public;
- L3: loss of cultural heritage
- L4: loss of economic value (structure and its content).

Losses which may appear in a service are as follows:

- L2: loss of service to the public;
- L4: loss of economic value (service and loss of activity).

NOTE In a service, loss of human life is not considered in this standard.

The relationship between source of damage, type of damage and loss is reported in Table 3 for structures and in Table 4 for services.

Table 3 – Damages and loss in a structure according to different points of strike of lightning

Point of strike		Source of damage	Type of damage	Type of loss
Structure		S1	D1 D2 D3	L1, L4** L1, L2, L3, L4 L1*, L2, L4
Near a structure		S2	D3	L1*, L2, L4
Service connected to the structure		S3	D1 D2 D3	L1, L4** L1, L2, L3, L4 L1*, L2, L4
Near a service		S4	D3	L1*, L2, L4
* Only for structures with risk of explosion and for hospitals or other structures where failure of internal systems immediately endangers human life.				
** Only for properties where animals may be lost.				

Table 4 – Damages and loss in a service according to different points of strike of lightning

Point of strike	Source of damage	Type of damage	Type of loss
Service	S3	D2 D3	L2, L4
Near the service	S4	D3	
Supplied structure	S1	D2 D3	

Types of loss resulting from types of damage and the corresponding risks are reported in Figure 1.

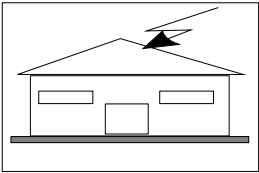
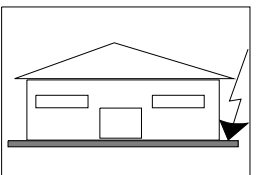
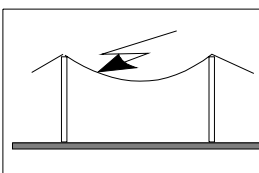
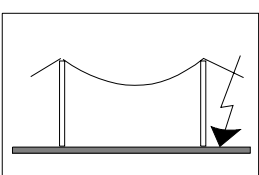
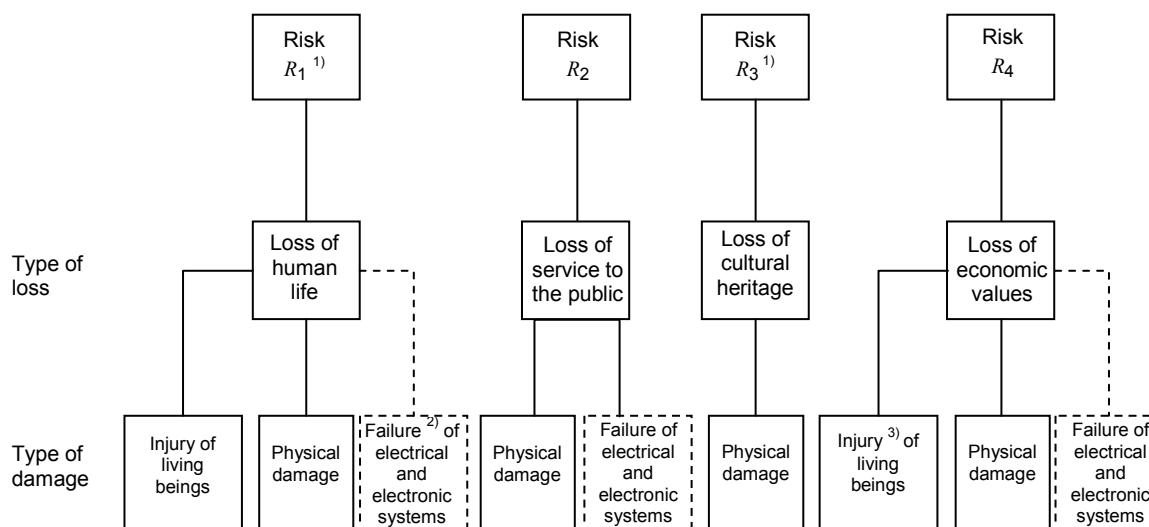

¹⁾ Only for structures.

²⁾ Only for hospitals or other structures where failure on internal systems immediately endanger human life.

³⁾ Only for properties where animals may be lost.

Figure 1 – Types of loss and corresponding risks resulting from different types of damage

6 Need and economic convenience for lightning protection

6.1 Need for lightning protection

The need for lightning protection of an object to be protected in order to reduce the loss of social values L1, L2 and L3 shall be evaluated.

In order to evaluate whether or not lightning protection of an object is needed, a risk assessment in accordance with the procedures contained in IEC 62305-2 shall be made. The following risks shall be taken into account, corresponding to the types of loss reported in 5.3:

- R_1 : risk of loss of human life;
- R_2 : risk of loss of services to the public;
- R_3 : risk of loss of cultural heritage.

Protection against lightning is needed if the risk R (R_1 to R_3) is higher than the tolerable level R_T

$$R > R_T$$

In this case, protection measures shall be adopted in order reduce the risk R (R_1 to R_3) to the tolerable level R_T

$$R \leq R_T$$

If more than one type of loss could appear in the object to be protected, the condition $R \leq R_T$ shall be satisfied for each type of loss (L1, L2 and L3).

The values of tolerable risk R_T where lightning could result in the loss of items of social value should be under the responsibility of a competent national body.

NOTE 1 An authority having jurisdiction may specify the need for lightning protection for specific applications without requiring a risk assessment. In these cases, the required lightning protection level will be specified by the authority having jurisdiction. In some cases, a risk assessment may be performed as a technique by which to justify a waiver to these requirements.

NOTE 2 Detailed information on risk assessment and on the procedure for selection of protection measures is reported in IEC 62305-2.

6.2 Economic convenience of lightning protection

Besides the need for lightning protection for the object to be protected, it may be useful to evaluate the economic benefits of providing protection measures in order to reduce the economic loss L_4 .

In this case, the risk R_4 of loss of economic values should be assessed. The assessment of risk R_4 allows the evaluation of the cost of the economic loss with and without the adopted protection measures.

Lightning protection is cost effective if the sum of the cost C_{RL} of residual loss in presence of protection measures and the cost C_{PM} of protection measures is lower than the cost C_L of total loss without protection measures:

$$C_{RL} + C_{PM} < C_L$$

NOTE Detailed information on the evaluation of economic convenience of lightning protection is reported in IEC 62305-2.

7 Protection measures

Protection measures may be adopted in order to reduce the risk according to the type of damage.

7.1 Protection measures to reduce injury of living beings due to touch and step voltages

Possible protection measures include:

- adequate insulation of exposed conductive parts;
- equipotentialization by means of a meshed earthing system;
- physical restrictions and warning notices.

NOTE 1 Equipotentialization is not effective against touch voltages.

NOTE 2 An increasing of the surface resistivity of the soil inside and outside the structure may reduce the life hazard (see Clause 8 of IEC 62305-3).

7.2 Protection measures to reduce physical damage

Possible protection measures include:

- a) for structures
 - lightning protection system (LPS)

NOTE 1 When a LPS is installed, equipotentialization is a very important measure to reduce fire and explosion danger and life hazard. For more details see IEC 62305-3.

NOTE 2 Provisions limiting the development and propagation of the fire such as fire-proof compartments, extinguishers, hydrants, fire alarm and fire extinguishing installations, may reduce physical damage.

NOTE 3 Protected escape routes provide protection for personnel.

- b) for services
 - shielding wire

NOTE 4 For buried cables, a very effective protection is given by metal ducts.

7.3 Protection measures to reduce failure of electrical and electronic systems

Possible protection measures include:

- a) for structures
 - LEMP protection measures system (LPMS) consisting of the following measures to be used alone or in combination:
 - earthing and bonding measures;
 - magnetic shielding;
 - line routing;
 - “coordinated SPD protection” .
- b) for services
 - surge protective devices (SPDs) at different locations along the length of the line and at the line termination;
 - magnetic shields of cables.

NOTE 1 For buried cables, very effective protection is provided by a continuous metallic screen of adequate thickness.

NOTE 2 Route redundancy, redundant equipment, autonomous power generating sets, uninterruptible power systems, fluid storage systems, and automatic failure detection system are effective protection measures to reduce the loss of activity of the service.

NOTE 3 An increased withstand voltage of insulation of equipment and cables is an effective protection measure against failure due to overvoltages.

7.4 Protection measures selection

The selection of the most suitable protection measures shall be made by the designer and the owner according to the type and the amount of each kind of damage, and according to the technical and economical aspects of the different protection measures.

The criteria for risk assessment and for selection of the most suitable protection measures are given in IEC 62305-2.

Protection measures are effective provided that they comply with the requirements of relevant standards and are able to withstand the stress expected in the place of its installation.

8 Basic criteria for protection of structures and services

An ideal protection for structures and services would be to enclose the object to be protected within an earthed and perfectly conducting continuous shield of adequate thickness, and by providing adequate bonding, at the entrance point into the shield, of the services connected to the structure.

This would prevent the penetration of lightning current and related electromagnetic field into the object to be protected and prevent dangerous thermal and electrodynamic effects of current, as well as dangerous sparkings and overvoltages for internal systems.

In practice, it is often neither possible nor cost effective to go to such lengths to provide such optimum protection.

Lack of continuity of the shield and/or its inadequate thickness allows the lightning current to penetrate the shield causing:

- physical damage and life hazard
- failure of internal systems
- failure of the service and of the connected systems.

Protection measures, adopted to reduce such damages and relevant consequential loss, shall be designed for the defined set of lightning current parameters against which protection is required (lightning protection level).

8.1 Lightning protection levels (LPL)

For the aim of this standard, four lightning protection levels (I to IV) are introduced. For each LPL a set of maximum and minimum lightning current parameters is fixed.

NOTE 1 Protection against lightning whose maximum and minimum lightning current parameters exceed those relevant to LPL I is not considered in this standard.

NOTE 2 The probability of occurrence of lightning with minimum or maximum current parameters outside the range of values defined for LPL I is less than 2 %.

The maximum values of lightning current parameters relevant to LPL I will not be exceeded, with a probability of 99 %. According to the polarity ratio assumed (see Clause A.2), values taken from positive flashes will have probabilities below 10 %, while those from negative flashes will remain below 1 % (see Clause A.3).

The maximum values of lightning current parameters relevant to LPL I are reduced to 75 % for LPL II and to 50 % for LPL III and IV (linear for I , Q and di/dt , but quadratic for W/R). The time parameters are unchanged.

The maximum values of lightning current parameters for the different lightning protection levels are given in Table 5 and are used to design lightning protection components (e.g. cross-section of conductors, thickness of metal sheets, current capability of SPDs, separation distance against dangerous sparking) and to define test parameters simulating the effects of lightning on such components (see Annex D).

The minimum values of lightning current amplitude for the different LPL are used to derive the rolling sphere radius (see Clause A.4) in order to define the lightning protection zone LPZ 0_B which cannot be reached by direct strike (see 8.2 and Figures 2 and 3). The minimum values of lightning current parameters together with the related rolling sphere radius are given in Table 6. They are used for positioning of the air-termination system and to define the lightning protection zone LPZ 0_B (see 8.2).

Table 5 – Maximum values of lightning parameters according to LPL

First short stroke			LPL			
Current parameters	Symbol	Unit	I	II	III	IV
Peak current	I	kA	200	150	100	
Short stroke charge	Q_{short}	C	100	75	50	
Specific energy	W/R	MJ/ Ω	10	5,6	2,5	
Time parameters	T_1/T_2	$\mu\text{s}/\mu\text{s}$	10 / 350			
Subsequent short stroke			LPL			
Current parameters	Symbol	Unit	I	II	III	IV
Peak current	I	kA	50	37,5	25	
Average steepness	di/dt	kA/ μs	200	150	100	
Time parameters	T_1/T_2	$\mu\text{s}/\mu\text{s}$	0,25 / 100			
Long stroke			LPL			
Current parameters	Symbol	Unit	I	II	III	IV
Long stroke charge	Q_{long}	C	200	150	100	
Time parameter	T_{long}	s	0,5			
Flash			LPL			
Current parameters	Symbol	Unit	I	II	III	IV
Flash charge	Q_{flash}	C	300	225	150	

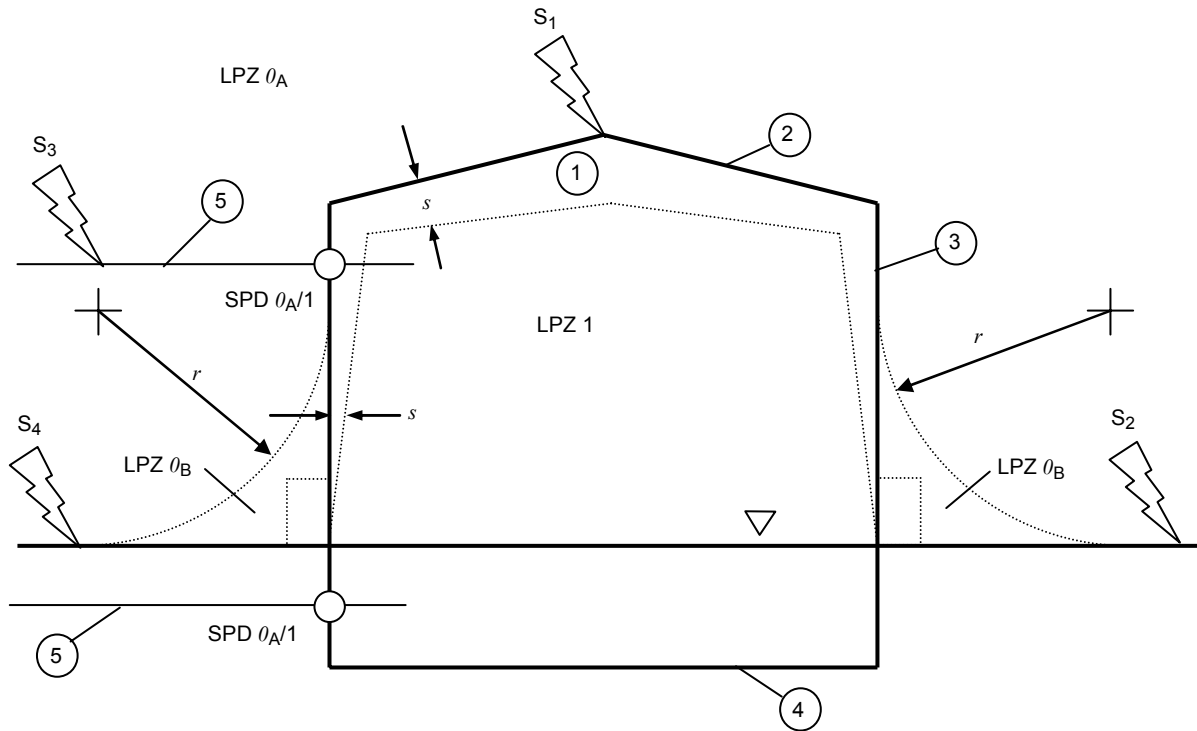

- | | | | |
|---|--------------------------|----------|---|
| 1 | Structure | S1 | Flash to the structure |
| 2 | Air termination system | S2 | Flash near to the structure |
| 3 | Down conductor system | S3 | Flash to a service connected to the structure |
| 4 | Earth termination system | S4 | Flash near a service connected to the structure |
| 5 | Incoming services | <i>r</i> | Rolling sphere radius |
| | | <i>s</i> | Separation distance against dangerous sparging |

Ground level

○ Lightning equipotential bonding by means of SPD

Direct flash, full lightning current

LPZ O_A Direct flash, full lightning current

LPZ O_B No direct flash, partial lightning or induced current

LPZ 1 No direct flash, limited lightning or induced current

Protected volume inside LPZ 1 must respect separation distance *s*

Figure 2 – LPZ defined by an LPS (IEC 62305-3)

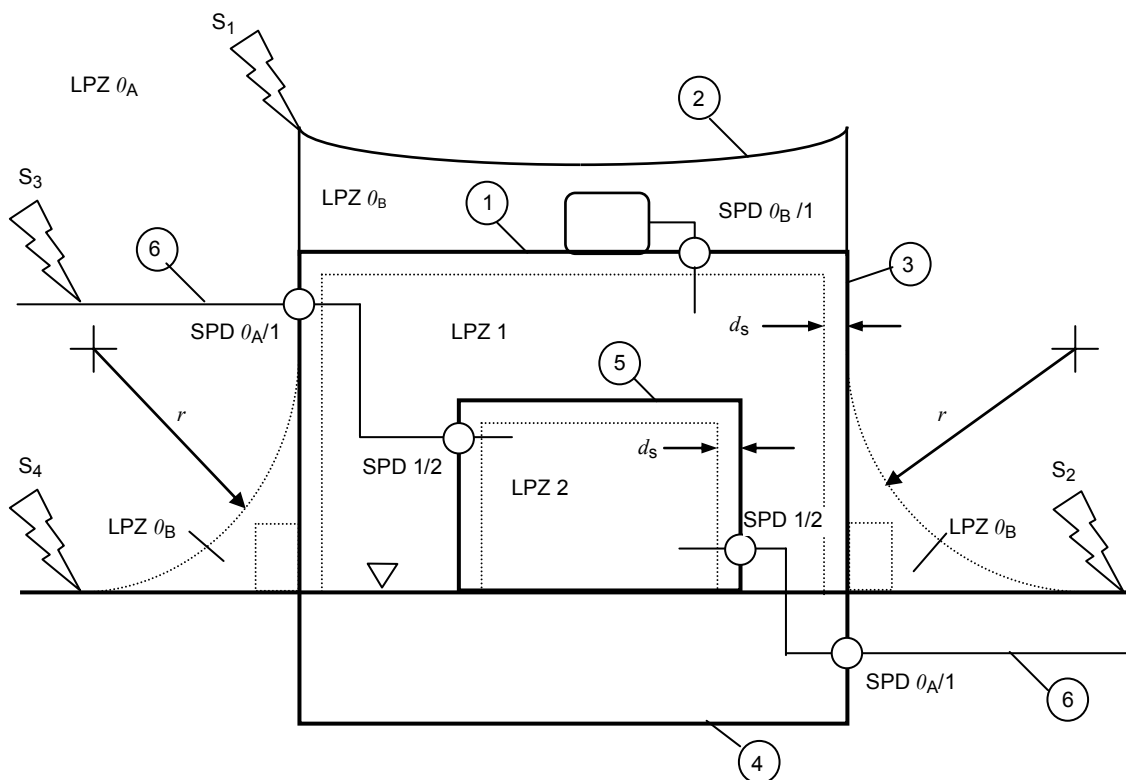

- | | | | |
|---|-------------------------------------|----------------------|---|
| 1 | Structure (shield of LPZ 1) | S1 | Flash to the structure |
| 2 | Air termination system | S2 | Flash near to the structure |
| 3 | Down conductor system | S3 | Flash to a service connected to the structure |
| 4 | Earth termination system | S4 | Flash near a service connected to the structure |
| 5 | Room (shield of LPZ 2) | <i>r</i> | Rolling sphere radius |
| 6 | Services connected to the structure | <i>d_s</i> | Safety distance against too high magnetic field |

Ground level

○ Lightning equipotential bonding by means SPD

LPZ *O_A* Direct flash, full lightning current, full magnetic field

LPZ *O_B* No direct flash, partial lightning or induced current, full magnetic field

LPZ 1 No direct flash, limited lightning or induced current, damped magnetic field

LPZ 2 No direct flash, induced currents, further damped magnetic field

Protected volumes inside LPZ 1 and LPZ 2 must respect safety distances *d_s*

Figure 3 – LPZ defined by protection measures against LEMP (IEC 62305-4)

Table 6 – Minimum values of lightning parameters and related rolling sphere radius corresponding to LPL

Interception criteria			LPL			
	Symbol	Unit	I	II	III	IV
Minimum peak current	I	kA	3	5	10	16
Rolling sphere radius	r	m	20	30	45	60

From the statistical distributions given in Figure A.5, a weighted probability can be determined that the lightning current parameters are smaller than the maximum values and respectively greater than the minimum values defined for each protection level (see Table 7).

Table 7 – Probabilities for the limits of the lightning current parameters

Probability that lightning current parameters	LPL			
	I	II	III	IV
Are smaller than the maximum values defined in Table 5	0,99	0,98	0,97	0,97
Are greater than the minimum values defined in Table 6	0,99	0,97	0,91	0,84

The protection measures specified in IEC 62305-3, IEC 62305-4 and IEC 62305-5 are effective against lightning whose current parameters are in the range defined by the LPL assumed for design. Therefore the efficiency of a protection measure is assumed equal to the probability with which lightning current parameters are inside such range.

8.2 Lightning protection zones (LPZ)

Protection measures such as LPS, shielding wires, magnetic shields and SPD determine lightning protection zones (LPZ).

LPZ downstream of the protection measure are characterized by significant reduction of LEMP than that upstream of the LPZ.

With respect to the threat of lightning, the following LPZs are defined (see Figures 2 and 3):

- LPZ O_A zone where the threat is due to the direct lightning flash and the full lightning electromagnetic field. The internal systems may be subjected to full or partial lightning surge current;
- LPZ O_B zone protected against direct lightning flashes but where the threat is the full lightning electromagnetic field. The internal systems may be subjected to partial lightning surge currents;
- LPZ 1 zone where the surge current is limited by current sharing and by SPDs at the boundary. Spatial shielding may attenuate the lightning electromagnetic field;
- LPZ 2, ..., n zone where the surge current may be further limited by current sharing and by additional SPDs at the boundary. Additional spatial shielding may be used to further attenuate the lightning electromagnetic field.

NOTE 1 In general, the higher the number of an individual zone, the lower the electromagnetic environment parameters.

As a general rule for protection, the object to be protected shall be in a LPZ whose electromagnetic characteristics are compatible with the capability of the object to withstand stress causing the damage to be reduced (physical damage, failure of electrical and electronic systems due to overvoltages).

NOTE 2 For most electrical and electronic systems and apparatus, information about withstand level can be supplied by manufacturer.

8.3 Protection of structures

8.3.1 Protection to reduce physical damage and life hazard

The structure to be protected shall be inside an LPZ 0_B or higher. This is achieved by means of a lightning protection system (LPS).

An LPS consists of both external and internal lightning protection systems (see Figure 2).

The functions of the external LPS are

- to intercept a lightning flash to the structure (with an air-termination system),
- to conduct the lightning current safely to earth (with a down-conductor system),
- to disperse it into the earth (with an earth-termination system).

The function of the internal LPS is to prevent dangerous sparking within the structure, using either equipotential bonding or a separation distance, s , (and hence electrical isolation) between the LPS components and other electrically conducting elements internal to the structure.

Four classes of LPS (I, II, III, IV) are defined as a set of construction rules, based on the corresponding LPL. Each set includes level-dependent (e.g. rolling sphere radius, mesh width etc.) and level-independent (e.g. cross-sections, materials etc.) construction rules.

Where surface resistivity of the soil outside, and of the floor inside the structure is not sufficiently high, life hazard due to touch and step voltages is reduced:

- outside the structure, by insulation of the exposed conductive parts, by equipotentialization of the soil by means of a meshed earthing system, by warning notice and by physical restrictions;
- inside the structure, by equipotential bonding of services at entrance point into the structure.

LPS shall comply with requirements of IEC 62305-3.

8.3.2 Protection to reduce the failure of internal systems

The protection against LEMP to reduce the risk of failure of internal systems shall limit:

- overvoltages due to lightning flashes to the structure resulting from resistive and inductive coupling;
- overvoltages due to lightning flashes near the structure resulting from inductive coupling;

- overvoltages transmitted by lines connected to the structure due to flashes to or near the lines;
- magnetic field directly coupling with internal systems.

NOTE Failure of apparatus due to electromagnetic fields directly radiated into the equipment are negligible provided that apparatus comply with radio frequency (RF) radiated emission and immunity tests defined by relevant EMC product standards (see IEC 62305-2 and IEC 62305-4).

The system to be protected shall be located inside a LPZ 1 or higher. This is achieved by means of magnetic shields attenuating the inducing magnetic field and/or suitable routing of wiring reducing the induction loop. Bonding shall be provided at the boundaries of LPZ for metal parts and systems crossing the boundaries. This bonding may be accomplished by means of bonding conductors or, when necessary, by surge protective devices (SPDs).

Protection measures for LPZ shall comply with IEC 62305-4.

Effective protection against overvoltages, causing failures of internal systems, may also be achieved by means of a “coordinated SPD protection”, limiting overvoltages below the rated impulse withstand voltage of the system to be protected.

SPDs shall be selected and installed according to the requirements of IEC 62305-4.

8.4 Protection of services

The service to be protected shall be

- inside an LPZ 0_B or higher to reduce physical damage. This is achieved by selecting underground instead of aerial routing or by using adequately positioned shielding wire, where effective according to the line characteristics or, in the case of pipes, by increasing the pipe thickness to an adequate value and ensuring the metallic continuity of pipes;
- inside an LPZ 1 or higher for protection against overvoltages causing failure of the service. This is achieved by reducing the level of the overvoltages induced by lightning by means of adequate magnetic shielding of cables, diverting overcurrent and limiting overvoltages by means of adequate SPDs.

Annex A (informative)

Parameters of lightning current

A.1 Lightning flashes to earth

Two basic types of flashes exist:

- downward flashes initiated by a downward leader from cloud to earth;
- upward flashes initiated by an upward leader from an earthed structure to cloud.

Mostly downward flashes occur in flat territory, and to lower structures, whereas for exposed and/or higher structures upward flashes become dominant. With effective height, the probability of a direct strike to the structure increases (see IEC 62305-2, Annex A) and the physical conditions change.

A lightning current consists of one or more different strokes:

- short strokes with duration less than 2 ms (Figure A.1)
- long strokes with duration longer than 2 ms (Figure A.2).

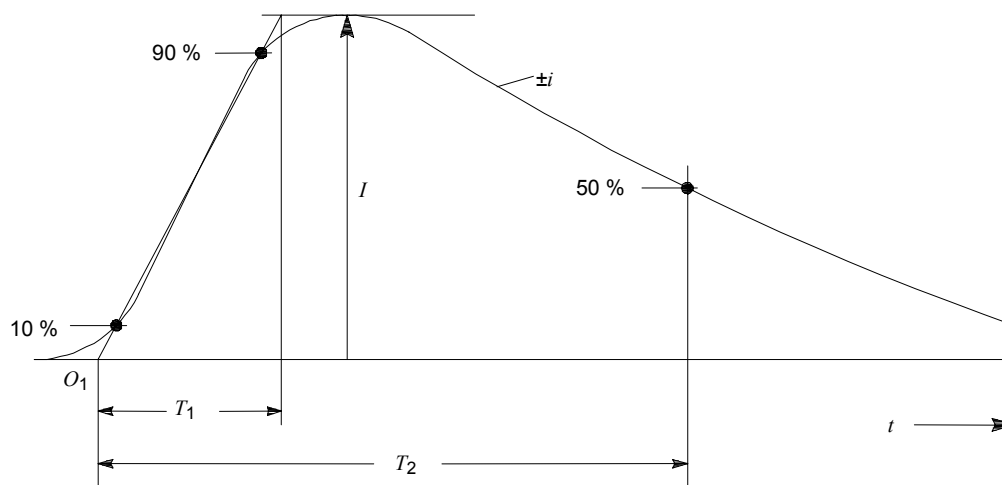

Key

O_1 virtual origin

I peak current

T_1 front time

T_2 time to half value

Figure A.1 – Definitions of short stroke parameters (typically $T_2 < 2$ ms)

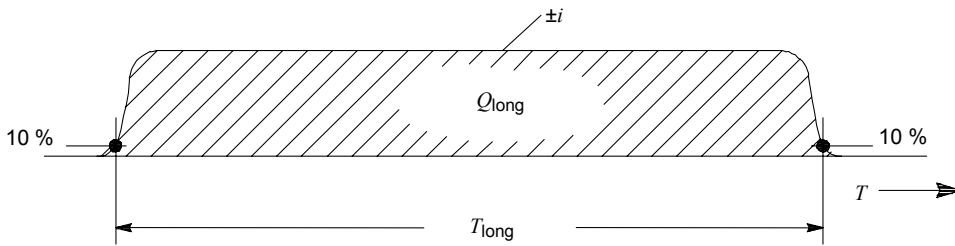

Key

T_{long} duration time

Q_{long} long stroke charge

**Figure A.2 – Definitions of long stroke parameters
(typically $2\text{ ms} < T_{long} < 1\text{ s}$)**

Further differentiation of strokes comes from their polarity (positive or negative) and from their position during the flash (first, subsequent, superimposed). The possible components are shown in Figure A.3 for downward flashes and in Figure A.4 for upward flashes.

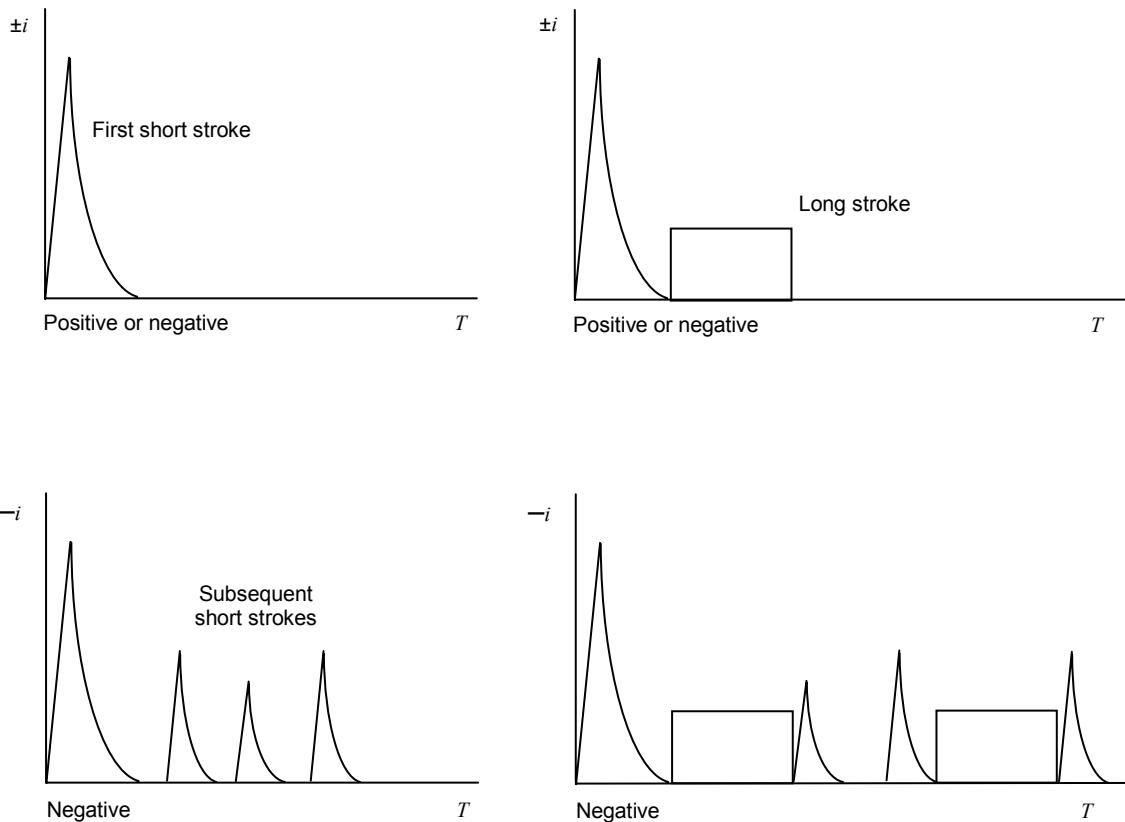

**Figure A.3 – Possible components of downward flashes
(typical in flat territory and to lower structures)**

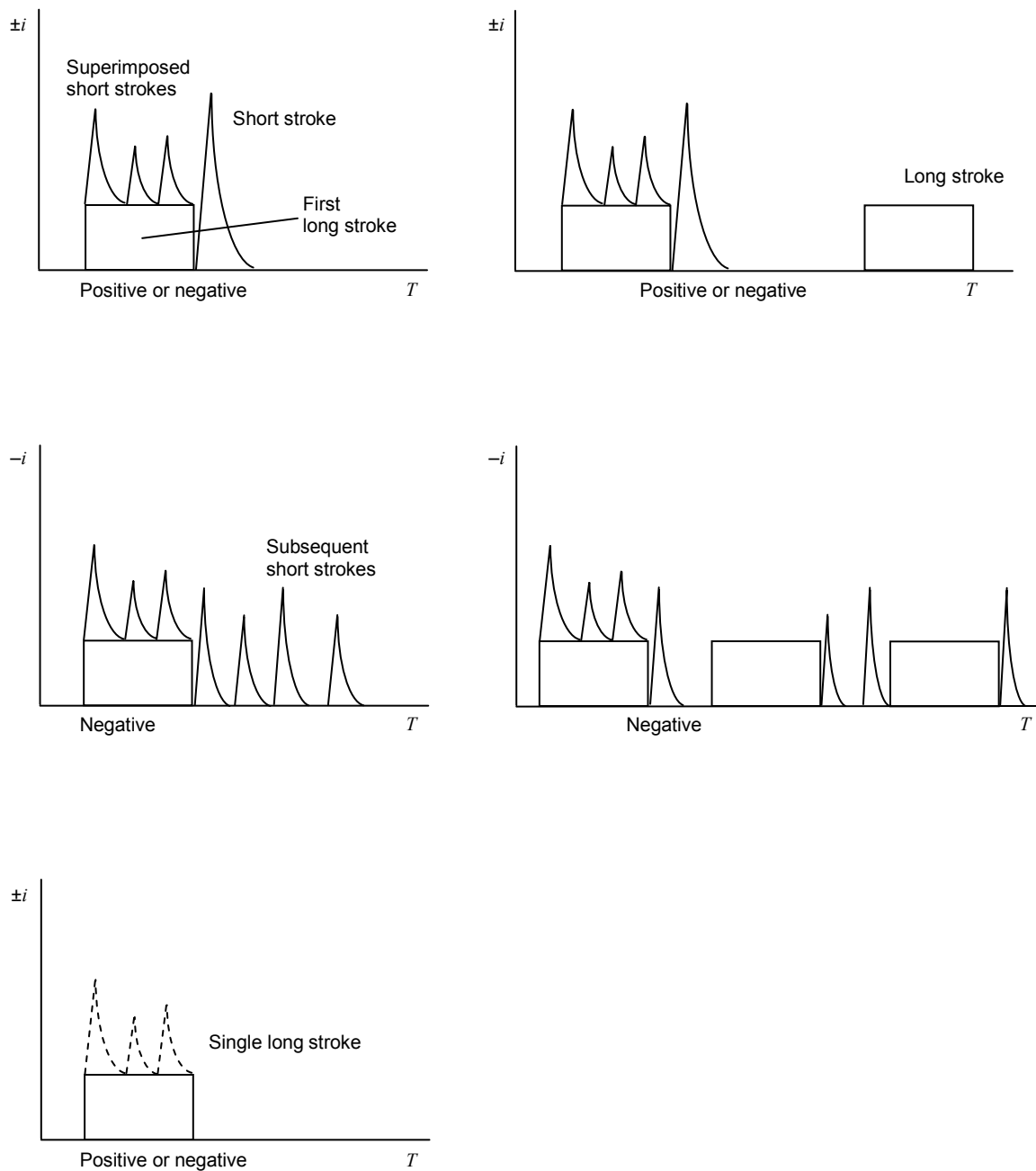

**Figure A.4 – Possible components of upward flashes
(typical to exposed and/or higher structures)**

The additional component in upward flashes is the first long stroke with or without up to some ten superimposed short strokes. But all short stroke parameters of upward flashes are less than those of downward flashes. A higher long stroke charge of upward flashes is not yet confirmed. Therefore the lightning current parameters of upward flashes are considered to be covered by the maximum values given for downward flashes. A more precise evaluation of lightning current parameters and their height dependency with regard to downward and upward flashes is under consideration.

A.2 Lightning current parameters

The lightning current parameters in this standard are based on the results of the International Council on Large Electrical Systems (CIGRE) data given in Table A.1. Their statistical distribution can be assumed to have a logarithmic normal distribution. The corresponding mean value μ and the dispersion σ_{\log} are given in Table A.2 and the distribution function is shown in Figure A.5. On this basis, the probability of occurrence of any value of each parameter can be determined.

A polarity ratio of 10 % positive and 90 % negative flashes is assumed. The polarity ratio is a function of the territory. If no local information is available, the ratio given herein should be used.

Table A.1 – Tabulated values of lightning current parameters taken from CIGRE (Electra No. 41 or No. 69*)^{[3], [4]}

Parameter	Fixed values for LPL I	Values			Type of stroke	Line in Figure A.5
		95 %	50 %	5 %		
I (kA)	50 200	4(98 %)	20(80 %)	90	*First negative short	1A+1B
		4,9	11,8	28,6	*Subsequent negative short	2
		4,6	35	250	First positive short (single)	3
Q_{flash} (C)	300	1,3	7,5	40	Negative flash	4
		20	80	350	Positive flash	5
Q_{short} (C)	100	1,1	4,5	20	First negative short	6
		0,22	0,95	4	Subsequent negative short	7
		2	16	150	First positive short (single)	8
W/R (kJ/Ω)	10 000	6	55	550	First negative short	9
		0,55	6	52	Subsequent negative short	10
		25	650	15 000	First positive short	11
di/dt_{max} (kA/μs)	20	9,1	24,3	65	*First negative short	12
		9,9	39,9	161,5	*Subsequent negative short	13
		0,2	2,4	32	First positive short	14
$di/dt_{30/90\%}$ (kA/μs)	200	4,1	20,1	98,5	*Subsequent negative short	15
Q_{long} (C)	200				Long	
t_{long} (s)	0,5				Long	
Front duration (μs)		1,8	5,5	18	First negative short	
		0,22	1,1	4,5	Subsequent negative short	
		3,5	22	200	First positive short (single)	
Stroke duration (μs)		30	75	200	First negative short	
		6,5	32	140	Subsequent negative short	
		25	230	2 000	First positive short (single)	
Time interval (ms)		7	33	150	Multiple negative strokes	
Total flash duration (ms)		0,15	13	1 100	Negative flash (all)	
		31	180	900	Negative flash (without single)	
		14	85	500	Positive flash	

NOTE The values of $I = 4$ kA and $I = 20$ kA correspond to a probability of 98 % and 80 %, respectively.

Table A.2 – Logarithmic normal distribution of lightning current parameters – Mean μ and dispersion σ_{\log} calculated from 95 % and 5 % values from CIGRE (Electra No. 41 or No. 69) ^{[3], [4]}

Parameter	Mean μ	Dispersion σ_{\log}	Stroke type	Line in Figure A.5
I (kA)	(61,1)	0,576	*First negative short (80 %)	1A
	33,3	0,263	*First negative short (80 %)	1B
	11,8	0,233	*Subsequent negative short	2
	33,9	0,527	First positive short (single)	3
Q_{flash} (C)	7,21	0,452	Negative flash	4
	83,7	0,378	Positive flash	5
Q_{short} (C)	4,69	0,383	First negative short	6
	0,938	0,383	Subsequent negative short	7
	17,3	0,570	First positive short (single)	8
W/R (kJ/ Ω)	57,4	0,596	First negative short	9
	5,35	0,600	Subsequent negative short	10
	612	0,844	First positive short	11
di/dt_{max} (kA/ μs)	24,3	0,260	*First negative short	12
	40,0	0,369	*Subsequent negative short	13
	2,53	0,670	First positive short	14
$di/dt_{30/90\%}$ (kA/ μs)	20,1	0,420	*Subsequent negative short	15
Q_{long} (C)	200		Long	
t_{long} (s)	0,5		Long	
Front duration (μs)	5,69	0,304	First negative short	
	0,995	0,398	Subsequent negative short	
	26,5	0,534	First positive short (single)	
Stroke duration (μs)	77,5	0,250	First negative short	
	30,2	0,405	Subsequent negative short	
	224	0,578	First positive short (single)	
Time interval (ms)	32,4	0,405	Multiple negative strokes	
Total flash duration (ms)	12,8	1,175	Negative flash (all)	
	167	0,445	Negative flash (without single)	
	83,7	0,472	Positive flash	

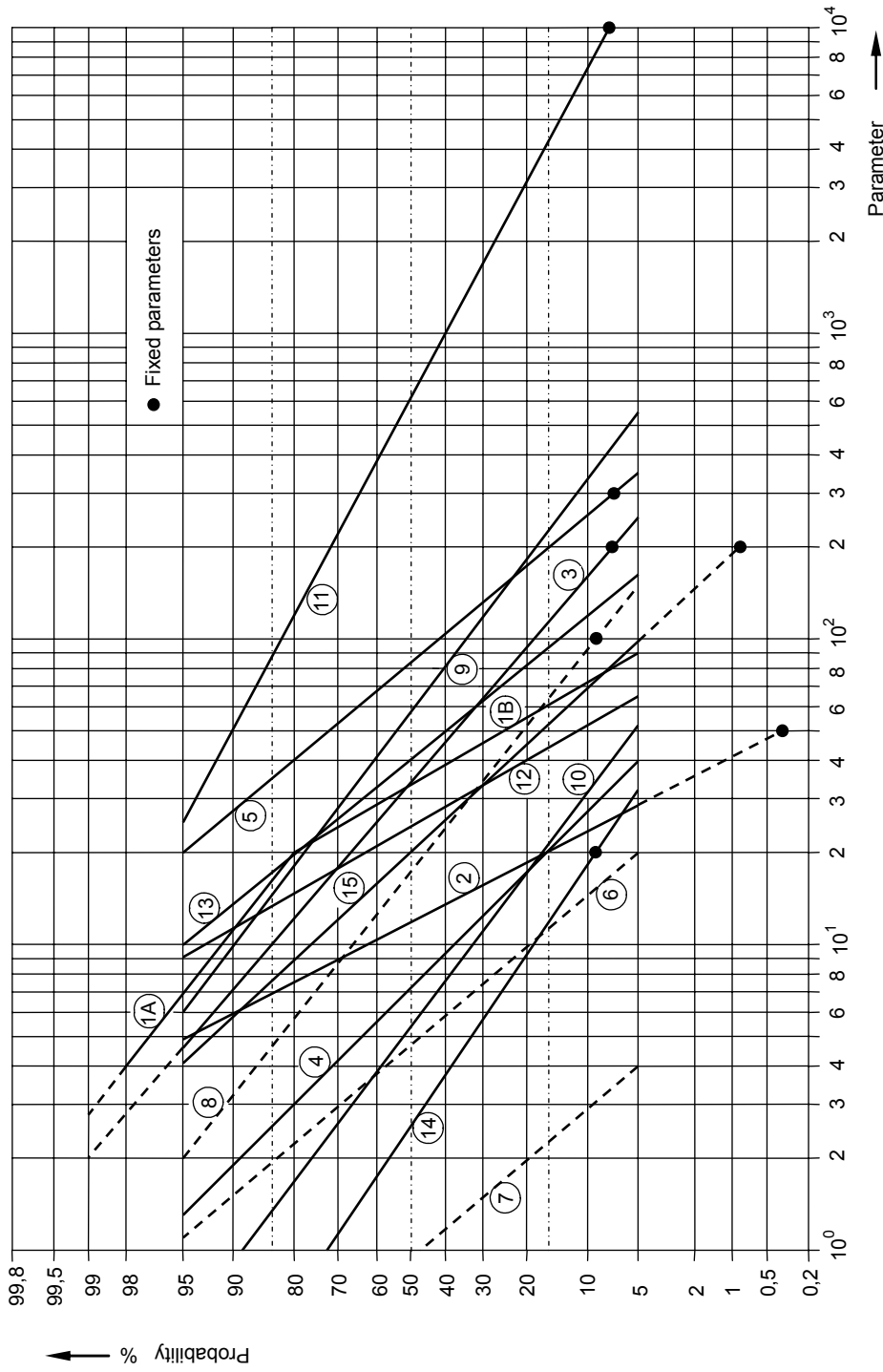

NOTE For numbering of curves see Tables A.1 and A.2.

Figure A.5 – Cumulative frequency distribution of lightning current parameters (lines through 95 % and 5 % value)

All values given in this standard relate to both downward and upward flashes.

NOTE The value of lightning parameters is usually obtained from measurement taken on tall objects. Statistical distribution of estimated lightning current peak values that does not consider the effect of tall objects is also available from lightning location systems.

A.3 Fixing the maximum lightning current parameters for LPL I

The mechanical effects of lightning are related to the peak value of the current (I), and to the specific energy (W/R). The thermal effects are related to the specific energy (W/R) when resistive coupling is involved and to the charge (Q) when arcs develop to the installation. Overvoltages and dangerous sparking caused by inductive coupling are related to the average steepness (di/dt) of the lightning current front.

Each of the single parameters (I , Q , W/R , di/dt) tend to dominate each failure mechanism. This shall be taken into account in establishing test procedures.

A.3.1 First short stroke and long stroke

The values of I , Q and W/R related to mechanical and thermal effects are determined from positive flashes (because their 10 % values are much higher than the corresponding 1 % values of the negative flashes). From Figure A.5 (lines 3, 5, 8, 11 and 14) the following values with probabilities below 10 % can be taken:

$$I = 200 \text{ kA}$$

$$Q_{\text{flash}} = 300 \text{ C}$$

$$Q_{\text{short}} = 100 \text{ C}$$

$$W/R = 10 \text{ MJ}/\Omega$$

$$di/dt = 20 \text{ kA}/\mu\text{s}$$

For a first short stroke according to Figure A.1, these values give an first approximation for the front time:

$$T_1 = I / (di/dt) = 10 \mu\text{s} \text{ (} T_1 \text{ is of minor interest)}$$

For an exponentially decaying stroke, the following formula for approximate charge and energy values applies ($T_1 \ll T_2$):

$$Q_{\text{short}} = (1/0,7) \cdot I \cdot T_2$$

$$W/R = (1/2) \cdot (1/0,7) \cdot I^2 \cdot T_2$$

These formulas, together with the values given above, lead to a first approximation for the time to half value:

$$T_2 = 350 \mu\text{s}$$

For the long stroke, its charge can be approximately calculated from:

$$Q_{\text{long}} = Q_{\text{flash}} - Q_{\text{short}} = 200 \text{ C}$$

Its duration time, according to Figure A.2, may be estimated from the flash duration time as:

$$T_{\text{long}} = 0,5 \text{ s}$$

A.3.2 Subsequent short stroke

The maximum value of average steepness di/dt related to the dangerous sparking caused by inductive coupling is determined from subsequent short strokes of negative flashes (because their 1 % values are much higher than the 1 % values from first negative strokes or the corresponding 10 % values of the positive flashes). From Figure A.5 (lines 2 and 15) the following values with probabilities below 1 % can be taken:

$$I = 50 \text{ kA}$$

$$di/dt = 200 \text{ kA}/\mu\text{s}$$

For a subsequent short stroke according to Figure A.1 these values give an first approximation for its front time of:

$$T_1 = I / (di/dt) = 0,25 \mu\text{s}$$

Its time to half value may be estimated from the stroke duration of negative subsequent short strokes:

$$T_2 = 100 \mu\text{s} \text{ (} T_2 \text{ is of minor interest).}$$

A.4 Fixing the minimum lightning current parameters

The interception efficiency of an LPS depends on the minimum lightning current parameters and on the related rolling sphere radius. The geometrical boundary of areas which are protected against direct lightning flashes can be determined using the rolling sphere method.

Following the electro-geometric model, the rolling sphere radius r (final jump distance) is correlated with the peak value of the first short stroke current. In an IEEE working group report^[5], the relation is given as

$$r = 10 \cdot I^{0,65} \tag{A.1}$$

where

r is the rolling sphere radius (m);

I is the peak current (kA).

For a given rolling sphere radius r it can be assumed that all flashes with peak values higher than the corresponding minimum peak value I will be intercepted by natural or dedicated air terminations. Therefore, the probability for the peak values of negative and positive first strokes from Figure A.5 (lines 1A and 3) is assumed to be the interception probability. Taking into account the polarity ratio of 10 % positive and 90 % negative flashes, the total interception probability can be calculated (see Table 7).

Annex B (informative)

Time functions of the lightning current for analysis purposes

The current waveshapes of:

- the first short stroke 10/350 μs
- the subsequent short strokes 0,25/100 μs

may be defined as:

$$i = \frac{I}{k} \cdot \frac{(t/\tau_1)^{10}}{1+(t/\tau_1)^{10}} \cdot \exp(-t/\tau_2) \quad (\text{B.1})$$

where

I is the peak current;

k is the correction factor for the peak current;

t is the time;

τ_1 is the front time constant;

τ_2 is the tail time constant.

For the current waveshapes of the first short stroke and the subsequent short strokes for different LPL, the parameters given in Table B.1 apply. The analytic curves are shown in Figures B.1 to B.4.

Table B.1 – Parameters for Equation B.1

Parameters	First short stroke			Subsequent short stroke		
	LPL			LPL		
	I	II	III-IV	I	II	III-IV
I (kA)	200	150	100	50	37,5	25
k	0,93	0,93	0,93	0,993	0,993	0,993
τ_1 (μs)	19	19	19	0,454	0,454	0,454
τ_2 (μs)	485	485	485	143	143	143

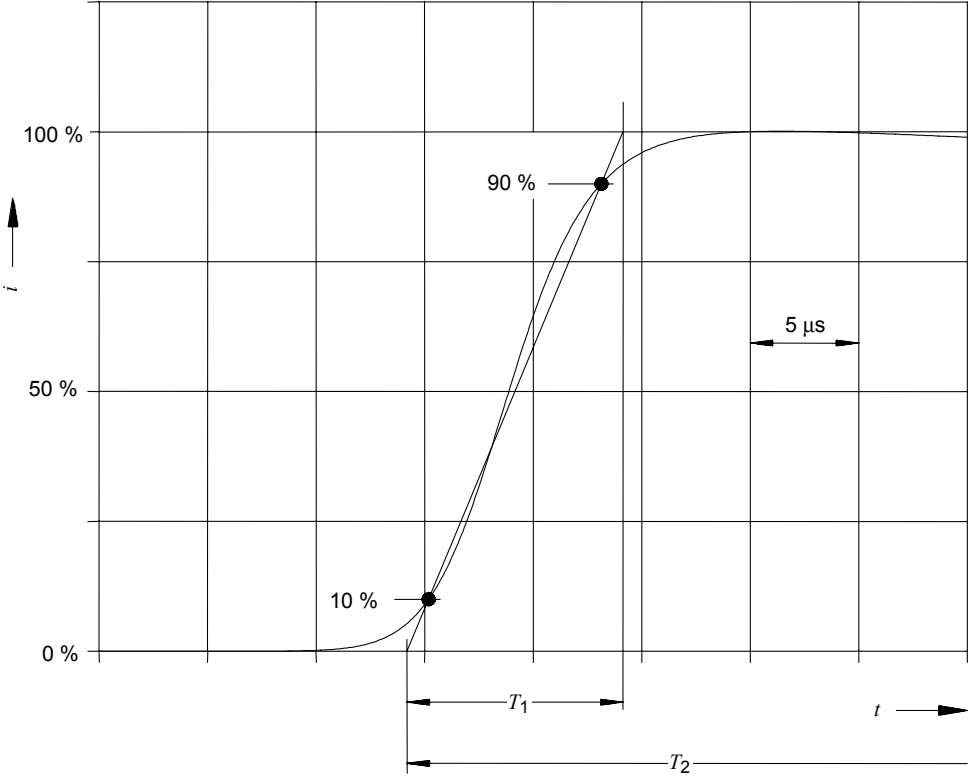

Figure B.1 – Waveshape of the current rise of the first short stroke

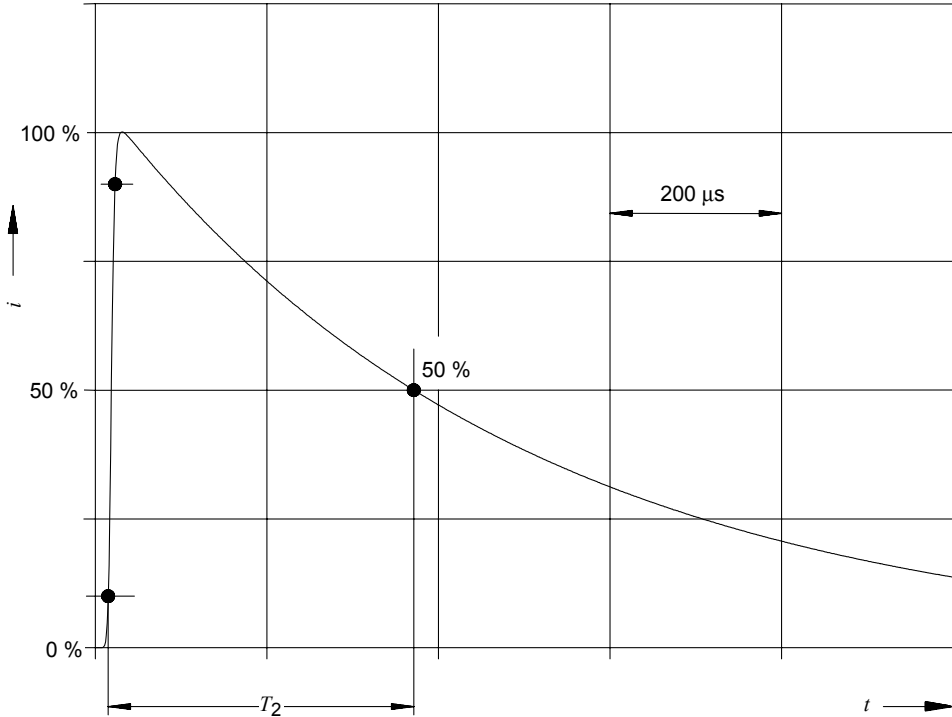

Figure B.2 – Wavelshape of the current tail of the first short stroke

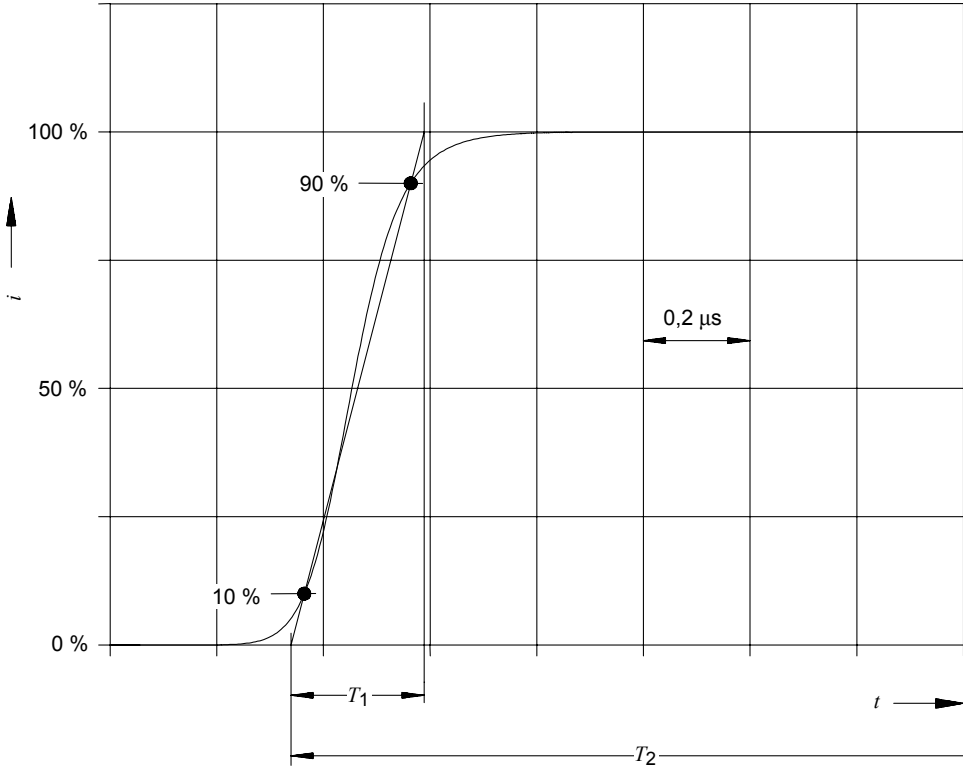

Figure B.3 – Wavelshape of the current rise of the subsequent short strokes

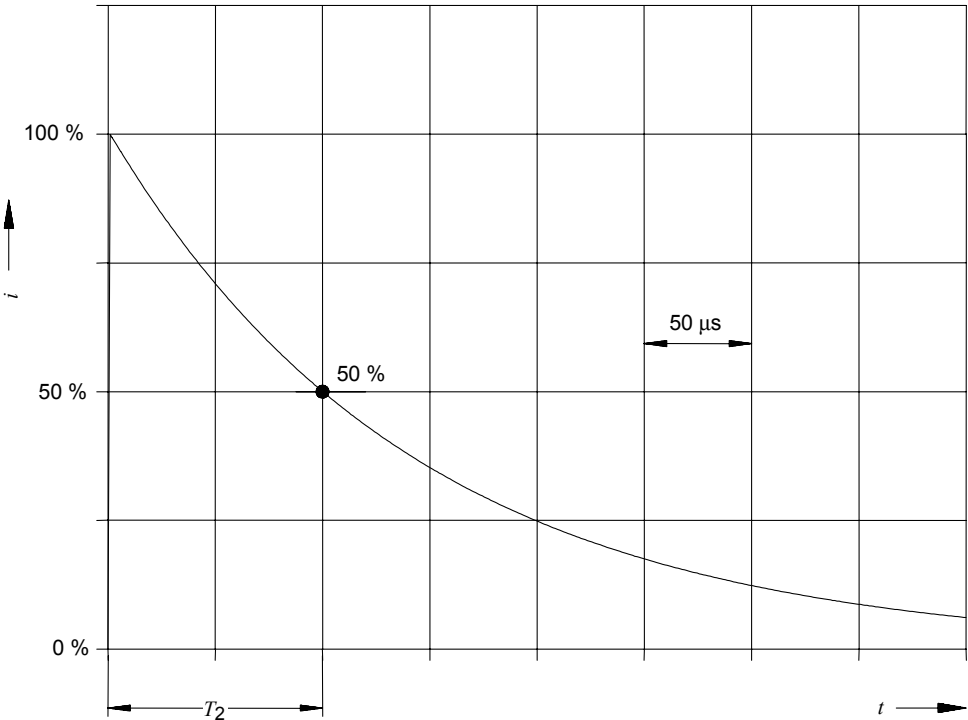
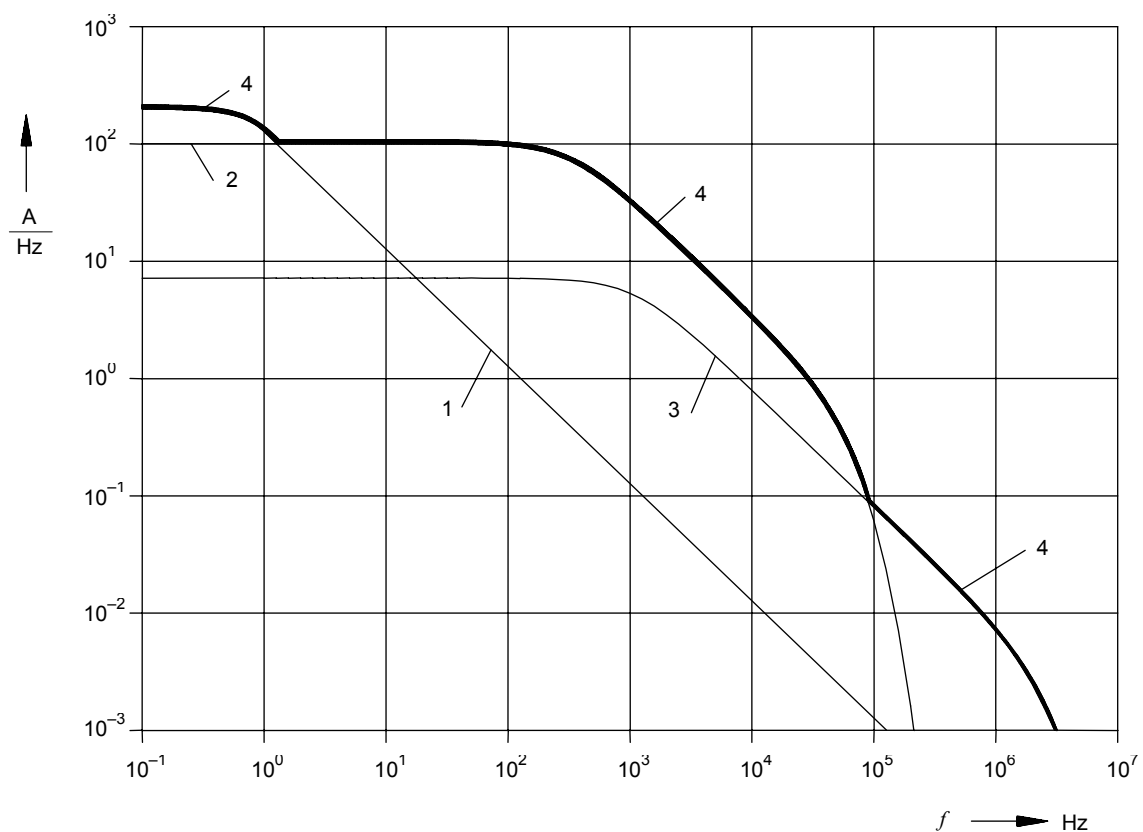

Figure B.4 – Waveshape of the current tail of the subsequent short strokes

The long stroke can be described by a rectangular waveshape with an average current I and a duration t_{long} according to Table 5.

From the analytic curves, the amplitude density of the lightning current (Figure B.5) can be derived.



1	Long stroke	400 A	0,5 s
2	First short stroke	200 kA	10/350 μ s
3	Subsequent short stroke	50 kA	0,25/100 μ s
4	Enveloping curve		

Figure B.5 – Amplitude density of the lightning current according to LPL I

Annex C (informative)

Simulation of the lightning current for test purposes

C.1 General

If an object is struck by lightning, the lightning current is distributed within the object. When testing individual protection measure components, this must be taken into account by choosing appropriate test parameters for each component. To this end, a system analysis has to be performed.

C.2 Simulation of the specific energy of the first short stroke and the charge of the long stroke

Test parameters are defined in Tables C.1 and C.2 and an example test generator is shown in Figure C.1. This generator may be used to simulate the specific energy of the first short stroke combined with the charge of the long stroke.

The tests may be used to assess mechanical integrity, freedom from adverse heating and melting effects.

The test parameters relevant for simulation of the first short stroke (peak current I , the specific energy W/R , and the charge Q_s) are given in Table C.1. These parameters shall be obtained in the same impulse. This can be achieved by an approximately exponentially decaying current with T_2 in the range of 350 μs .

The test parameters relevant for the simulation of the long stroke (charge Q_1 and duration T) are given in Table C.2.

Depending on the test item and the expected damage mechanisms, the tests for the first short stroke or the long stroke can be applied singly or as a combined test, where the long stroke follows the first short stroke immediately. Tests for arc melting should be performed using both polarities.

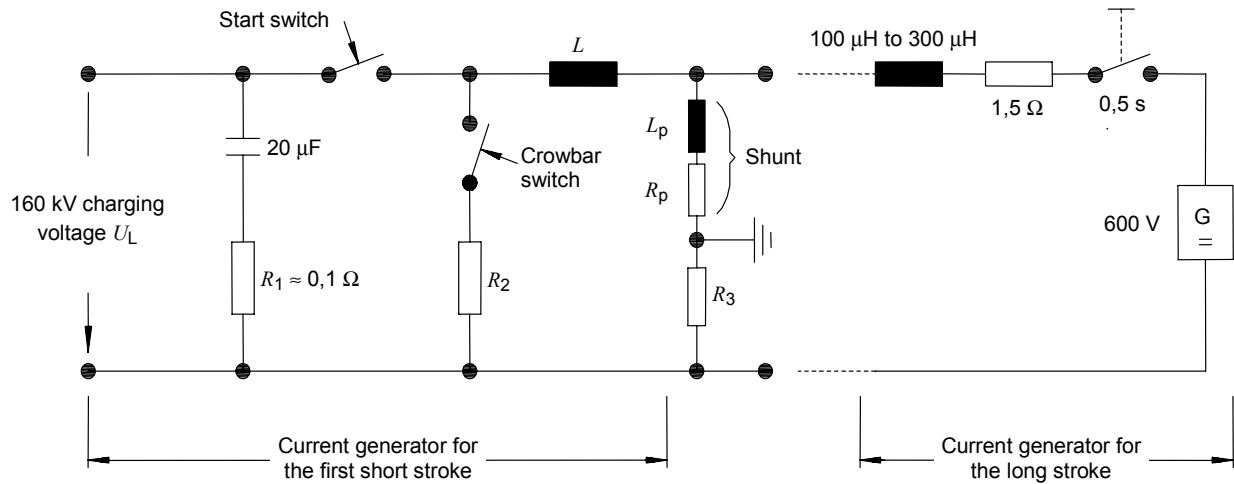

NOTE The values apply to LPL I.

Figure C.1 – Example test generator for the simulation of the specific energy of the first short stroke and the charge of the long stroke

Table C.1 – Test parameters of the first short stroke

Test parameters	LPL			Tolerance %
	I	II	III – IV	
Peak current <i>I</i> (kA)	200	150	100	±10
Charge <i>Q_s</i> (C)	100	75	50	±20
Specific energy <i>W/R</i> (MJ/Ω)	10	5,6	2,5	±35

Table C.2 – Test parameters of the long stroke

Test parameters	LPL			Tolerance %
	I	II	III – IV	
Charge <i>Q_{long}</i> (C)	200	150	100	±20
Duration <i>T</i> (s)	0,5	0,5	0,5	±10

C.3 Simulation of the front current steepness of the short strokes

The steepness of the current determines the magnetically induced voltages in loops being installed near conductors carrying lightning currents.

The current steepness of a short stroke is defined as the rise of the current Δi during rise time Δt (Figure C.2). The test parameters relevant for the simulation of this current steepness are given in Table C.3. Example test generators are shown in Figures C.3 and C.4, (which may be used to simulate the front steepness of a lightning current associated with a direct lightning strike). The simulation can be done for a short first stroke and a subsequent short stroke.

NOTE This simulation covers the front current steepness of short strokes. The tail of the current has no influence on this kind of simulation.

The simulation according to Clause C.2 may be applied independently or in combination with the simulation according to Clause C.1.

For further information on test parameters simulating the effects of lightning on LPS components, see Annex D.

Table C.3 – Test parameters of the short strokes

Test parameters	LPL			Tolerance %
	I	II	III – IV	
First short stroke				
Δi (kA)	200	150	100	± 10
Δt (μs)	10	10	10	± 20
Subsequent short strokes				
Δi (kA)	50	37,5	25	± 10
Δt (μs)	0,25	0,25	0,25	± 20

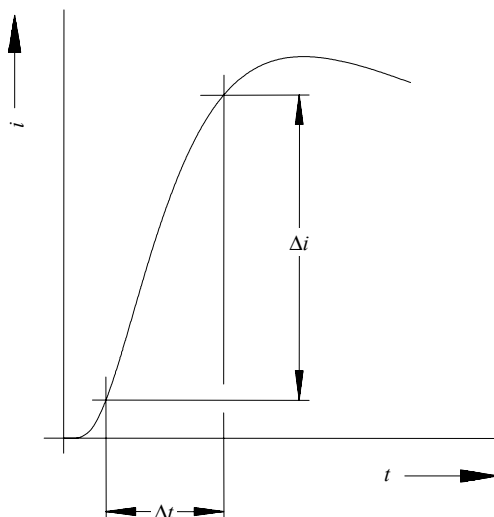
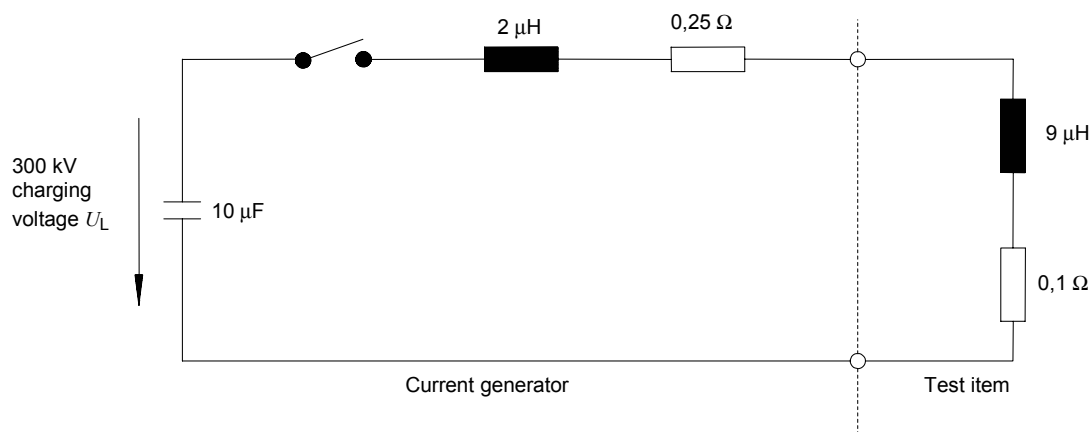
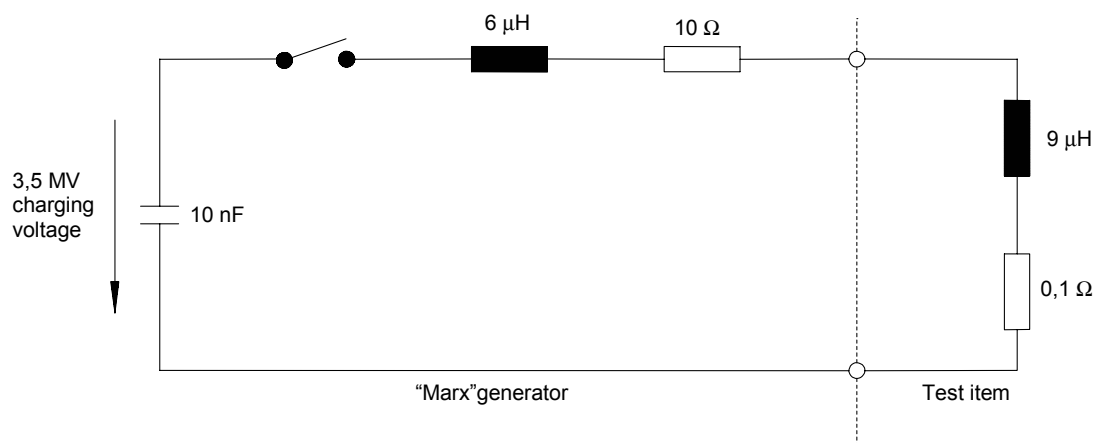

Figure C.2 – Definition for the current steepness in accordance with Table C.3



NOTE These values apply to LPL I.

Figure C.3 – Example test generator for the simulation of the front steepness of the first short stroke for large test items



NOTE These values apply to LPL I.

Figure C.4 – Example test generator for the simulation of the front steepness of the subsequent short strokes for large test items

Annex D (informative)

Test parameters simulating the effects of lightning on LPS components

D.1 General

This Annex D gives the basic parameters to be used in a laboratory to simulate the effects of lightning. This annex covers all the components of an LPS subjected to all or a major part of the lightning current and shall be used in conjunction with the standards specifying the requirements and the tests for each specific component.

NOTE Parameters relevant to system aspects (e.g. for the coordination of surge protective devices) are not considered in this annex.

D.2 Current parameters relevant to the point of strike

The lightning current parameters playing a role in the physical integrity of an LPS are in general the peak current I , the charge Q , the specific energy W/R , the duration T and the average steepness of the current di/dt . Each parameter tends to dominate a different failure mechanism, as analysed in detail below. The current parameters to be considered for tests are combinations of these values, selected to represent in laboratory the actual failure mechanism of the part of the LPS being tested. The criteria for the selection of the outstanding quantities are given in Clause D.5.

Table D.1 records the maximum values of I , Q , W/R , T and di/dt to be considered for tests, as a function of the protection level required.

Table D.1 – Summary of the lightning threat parameters to be considered in the calculation of the test values for the different LPS components and for the different LPL

Component	Main problem	Lightning threat parameters					Notes
Air termination	Erosion at attachment point (e.g. thin metal sheets)	LPL	Q_{long} C	T			
		I	200	<1 s (apply Q_{long} in a single shot)			
		II	150				
		III-IV	100				
Air termination and down conductor	Ohmic heating	LPL	W/R kJ/ Ω	T			Dimensioning with IEC 62305-3 render testing superfluous
		I	10 000	Apply W/R in an adiabatic configuration			
		II	5 600				
	III-IV	2 500					
	Mechanical effects	LPL	I kA	W/R kJ/ Ω			
		I	200	10 000			
II		150	5 600				
III-IV	100	2 500					
Connecting components	Combined effects (thermal, mechanical, and arcing)	LPL	I kA	W/R [kJ/ Ω]	T		
		I	200	10 000	<2 ms (apply I and W/R in a single pulse)		
		II	150	5 600			
		III-IV	100	2 500			
Earth terminations	Erosion at attachment point	LPL	Q_{long} C	T			Dimensioning usually determined by mechanical/chemical aspects (corrosion etc.)
		I	200	<1s (apply Q_{long} in a single shot)			
		II	150				
		III-IV	100				
SPDs containing spark gaps	Combined effects (thermal, mechanical and arcing)	LPL	I kA	Q_{short} C	W/R kJ/ Ω	di/dt kA/ μ s	Apply I , Q_{short} and W/R in a single pulse (duration $T < 2$ ms); apply $\Delta i/\Delta t$ in a separate pulse
		I	200	100	10 000	200	
		II	150	75	5 600	150	
		III-IV	100	50	2 500	100	
SPDs containing metal-oxide resistor blocks	Energy effects (overload)	LPL	Q_{short} C				Both aspects need to be checked.
		I	100				
		II	75				
	Dielectric effect (flashover/cracking)	LPL	I kA	T			Separate tests can be considered
		I	200	<2 ms (apply I in a single pulse)			
		II	150				
III-IV	100						

D.3 Current sharing

The parameters given in the Table D.3 are relevant to the lightning current at the point of strike. In fact, the current flows to earth through more than one path, as several down conductors and natural conductors are normally present in an external LPS. Additionally, different services normally enter the protected structure (water and gas pipes, power and telecommunication lines etc.). For the determination of the parameters of the actual current flowing in specific components of an LPS, the sharing of the current has to be taken into account. Preferably, current amplitude and waveshape through a component at a specific location of the LPS should be evaluated. Where an individual evaluation is not possible, the current parameters may be assessed by means of the following procedures.

For the evaluation of the current sharing within the external LPS, the configuration factor k_c (see Annex C of IEC 62305-3) may be adopted. This factor provides an estimate of the share of the lightning current flowing in down conductors of the external LPS under worst-case conditions.

For the evaluation of the current sharing in presence of external conductive parts and power and telecommunication lines connected to the protected structure, the approximate values of k_e and k'_e considered in Annex E may be adopted.

The above-described approach is applicable for the evaluation of the peak value of the current flowing in one particular path to earth. The calculation of the other parameters of the current is carried out as follows:

$$I_p = kI \quad (D.1)$$

$$Q_p = kQ \quad (D.2)$$

$$(W/R)_p = k^2 (W/R) \quad (D.3)$$

$$\left. \frac{di}{dt} \right|_p = k \left. \frac{di}{dt} \right| \quad (D.4)$$

where

x_p is the value of the quantity considered (peak current I_p , charge Q_p , specific energy (W/R)_p, current steepness $(di/dt)_p$) relevant to a particular path to earth "p";

x is the value of the quantity considered (peak current I , charge Q , specific energy (W/R), current steepness (di/dt)) relevant to the total lightning current;

k is the current sharing factor;

k_c is the current sharing factor for external LPS (see Annex C of IEC 62305-3);

k_e, k'_e are the current sharing factors in the presence of external conductive parts and power and telecommunication lines entering the protected structure (see Annex E).

D.4 Effects of lightning current causing possible damage

D.4.1 Thermal effects

Thermal effects linked with lightning current are relevant to the resistive heating caused by the circulation of an electric current flowing through the resistance of a conductor or into an LPS. Thermal effects are also relevant to the heat generated in the root of the arcs at the attachment point and in all the isolated parts of an LPS involved in arc development (e.g. spark gaps).

D.4.1.1 Resistive heating

Resistive heating takes place in any component of an LPS carrying a significant part of the lightning current. The minimum cross-sectional area of conductors must be sufficient to prevent overheating of the conductors to a level that would present a fire hazard to the surroundings. Despite the thermal aspects discussed in D.4.1, the mechanical withstand and durability criteria have to be considered for parts exposed to atmospheric conditions and/or corrosion. The evaluation of conductor heating due to lightning current flow is sometimes necessary when problems can arise because of the risk of personal injury and of fire or explosion damages.

Guidance is given below to evaluate the temperature rise of conductors subjected to the flow of a lightning current.

An analytical approach is presented as follows:

The instantaneous power dissipated as heat in a conductor due to an electrical current is expressed as:

$$P(t) = i^2 R \quad (D.5)$$

The thermal energy generated by the complete lightning pulse is therefore the ohmic resistance of the lightning path through the LPS component considered, multiplied by the specific energy of the pulse. This energy is expressed in units of Joules or Watt / seconds

$$W = R \cdot \int i^2 \cdot dt \quad (D.6)$$

In a lightning discharge, the high specific energy phases of the lightning flash are too short in duration for any heat generated in the structure to be dispersed significantly. The phenomenon is therefore to be considered adiabatic.

The temperature of the conductors of the LPS can be evaluated as follows:

$$\theta - \theta_0 = \frac{1}{\alpha} \left(\exp \left\{ \frac{W}{R} \cdot \frac{\alpha \cdot \rho_0}{q^2 \cdot \gamma \cdot C_w} \right\} - 1 \right) \quad (D.7)$$

where

$\theta - \theta_0$ temperature rise of the conductors (K);

α temperature coefficient of the resistance (1/(K));

W/R specific energy of the current impulse (J/Ω);

ρ_0 specific ohmic resistance of the conductor at ambient temperature (Ωm);

q cross-section area of the conductor (m²);

γ	material density (kg/m ³);
C_w	thermal capacity (J/kgK);
θ_s	melting temperature (°C);
c_s	latent heat of melting (J/kg).

Characteristic values of the physical parameters reported in Equation (D.7), for different materials used in LPS are recorded in Table D.2. Table D.3 reports, as an example of application of this equation, the temperature rise of conductors made of different materials, as a function of the W/R and of the conductor cross-section area.

The typical lightning stroke is characterized by a short duration stroke (time to half value of a few 100 μ s) and high current peak value. Under these circumstances, the skin effect should also be taken into consideration. However, in most of the practical cases linked with LPS components, the material characteristics (dynamic magnetic permeability of the LPS conductor) and the geometrical configurations (cross-sectional area of the LPS conductor) reduce the contribution of the skin effect in the temperature rise of the conductor to negligible levels.

The component of the lightning flash most relevant to this heating mechanism is the first return stroke.

Table D.2 – Physical characteristics of typical materials used in LPS components

Quantity	Material			
	Aluminium	Mild steel	Copper	Stainless steel*
ρ_0 (Ω m)	29 10 ⁻⁹	120 10 ⁻⁹	17,8 10 ⁻⁹	0,7 10 ⁻⁶
α (1/K)	4,0 10 ⁻³	6,5 10 ⁻³	3,92 10 ⁻³	0,8 10 ⁻³
γ (kg/m ³)	2 700	7 700	8 920	8 10 ³
θ_s (°C)	658	1 530	1 080	1 500
C_s (J/kg)	397 10 ³	272 10 ³	209 10 ³	–
c_w (J/kgK)	908	469	385	500

* Austenitic non magnetic.

Table D.3 – Temperature rise for conductors of different sections as a function of W/R

Cross-section mm ²	Material											
	Aluminium			Mild steel			Copper			Stainless steel*		
	W/R MJ/ Ω			W/R MJ/ Ω			W/R MJ/ Ω			W/R MJ/ Ω		
	2,5	5,6	10	2,5	5,6	10	2,5	5,6	10	2,5	5,6	10
4	–	–	–	–	–	–	–	–	–	–	–	–
10	564	–	–	–	–	–	169	542	–	–	–	–
16	146	454	–	1 120	–	–	56	143	309	–	–	–
25	52	132	283	211	913	–	22	51	98	940	–	–
50	12	28	52	37	96	211	5	12	22	190	460	940
100	3	7	12	9	20	37	1	3	5	45	100	190

* Austenitic non magnetic.

D.4.1.2 Attachment point thermal damage

Attachment point thermal damage can be observed on all components of an LPS on which an arc development takes place, i.e. air-termination systems, spark gaps, etc.

Material melting and erosion can occur at the attachment point. In fact, in the arc root area there is a large thermal input from the arc root itself, as well as a concentration of ohmic heating due to the high current densities. Most of the thermal energy is generated at or very close to the surface of the metal. The heat generated in the immediate root area is in excess of that which can be absorbed into the metal by conduction and the excess is irradiated or lost in melting or vaporizing of metal. The severity of the process is linked to the current amplitude and to the duration.

D.4.1.2.1 General

Several theoretical models have been developed for the calculation of thermal effects on metal surfaces at the attachment point of a lightning channel. For sake of simplicity, this standard will report only the anode-or-cathode voltage drop model. The application of this model is particularly effective for thin metal skins. In all cases, it gives conservative results as it postulates that all the energy injected in the lightning attachment point is used to melt or vaporize conductor material, neglecting the heat diffusion within the metal. Other models introduce the dependence of the lightning attachment point damage on the duration of the current impulse.

D.4.1.2.2 Anode-or-cathode voltage drop model

The energy input W at the arc root is assumed as given by the anode/cathode voltage drop $u_{a,c}$ multiplied by the charge Q of the lightning current:

$$W = \int u_{a,c} i dt = u_{a,c} \int i dt = u_{a,c} \cdot Q \quad (D.8)$$

As $u_{a,c}$ is fairly constant in the current range considered here, the charge of the lightning current (Q) is primarily responsible for the energy conversion in the arc root.

The anode-or-cathode voltage drop $u_{a,c}$ has a value of a few tens of volts.

A simplified approach assumes that all of the energy developed at the arc root is used only for melting. Equation (D.9) uses this assumption but leads to an overestimate of the melted volume

$$V = \frac{u_{a,c} Q}{\gamma} \cdot \frac{1}{c_w (\theta_s - \theta_u) + c_s} \quad (D.9)$$

where

V is the volume of metal melted (m^3);

$u_{a,c}$ is the anode-or-cathode voltage drop (assumed as constant) (V);

Q is the charge of the lightning current (C);

γ is the material density (kg/m^3);

c_w is the thermal capacity (J/kgK);

θ_s is the melting temperature ($^{\circ}C$);

θ_u is the ambient temperature ($^{\circ}C$);

c_s is the latent heat of melting (J/kg).

Characteristic values of the physical parameters reported in this equation, for different materials used in an LPS, are recorded in Table D.1.

Basically, the charge to be considered is the sum of the charge of the return stroke and the lightning continuing current. Laboratory experience has revealed that the effects of the return stroke charge are of minor importance when compared to the effects of the continuing current.

D.4.2 Mechanical effects

Mechanical effects caused by the lightning current depend on the amplitude and the duration of the current as well as on the elastic characteristics of the affected mechanical structure. Mechanical effects also depend on the friction forces acting between parts of the LPS in contact with one another, where relevant.

D.4.2.1 Magnetic interaction

Magnetic forces occur between two current-carrying conductors or, if only one current-carrying conductor exists, forms a corner or a loop.

When a current flows through a circuit, the amplitude of the electrodynamic forces developed at the various positions of the circuit depend on both the amplitude of the lightning current and the geometrical configuration of the circuit. The mechanical effect of these forces, however, depends not only on their amplitude but also on the general form of the current, duration, as well as on the geometrical configuration of the installation.

D.4.2.1.1 Electrodynamic forces

Electrodynamic forces developed by a current, i , flowing into a conductor having long parallel sections of length l and distance d (long and small loop), as shown in Figure D.1, can be approximately calculated using the following equation:

$$F(t) = \frac{\mu_0}{2\pi} i^2(t) \frac{l}{d} = 2 \cdot 10^{-7} \cdot i^2(t) \cdot \frac{l}{d} \quad (\text{D.10})$$

where

$F(t)$ is the electrodynamic force (N);

i is the current (A);

μ_0 is the magnetic permeability of air ($4\pi \cdot 10^{-7}$ H/m);

l is the length of conductors (m);

d is the distance between the straight parallel sections of the conductor (m).

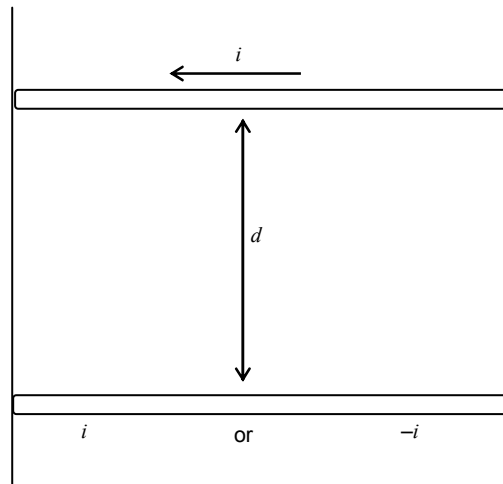

Figure D.1 – General arrangement of two conductors for the calculation of electrodynamic force

In an LPS a typical example is given by a symmetric corner arrangement of conductors, forming an angle of 90° , with a clamp positioned in the vicinity of the corner as shown in Figure D.2. The diagram of the stresses for this configuration is reported in Figure D.3. The axial force on the horizontal conductor tends to pull the conductor out of the clamp. The numerical value of the force along the horizontal conductor, considering a peak current value of 100 kA and a length of a vertical conductor of 0,5 m, is shown in Figure D.4.

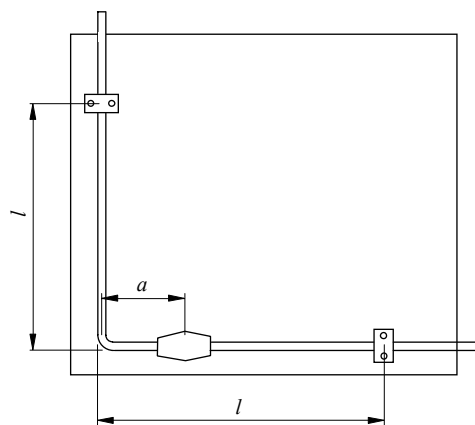

Figure D.2 – Typical conductor arrangement in an LPS

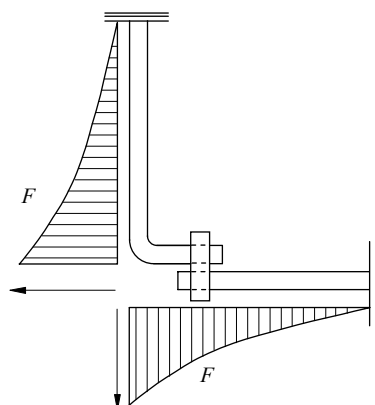
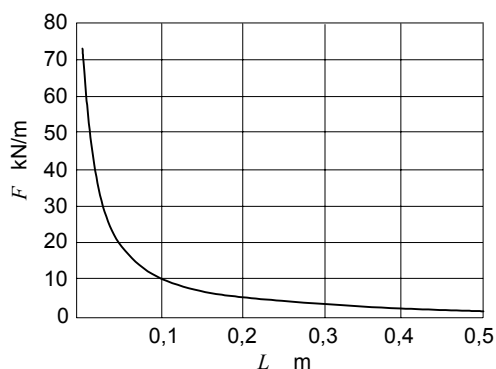

Figure D.3 – Diagram of the stresses for the configuration of Figure D.2



NOTE Peak current value 100 kA and length of vertical conductor 0,5 m.

Figure D.4 – Force per unit length along the horizontal conductor of Figure D.2

D.4.2.1.2 Effects of electrodynamic forces

In terms of amplitude of applied force, the instantaneous value of the electrodynamic force $F(t)$ is proportional to the square of the instantaneous current $I(t)^2$. In terms of the stress development within the mechanical LPS structure, expressed by the product of the elastic deformation $\delta(t)$ and the elastic constant k of the LPS structure, two effects should be considered. The natural mechanical frequency (linked with the elastic behaviour of the LPS structure) and the permanent deformation of the LPS structure (linked with its plastic behaviour) are the most important parameters. Moreover, in many cases the effect of the friction forces within the structure are also of significant importance.

The amplitude of the vibrations of the elastic LPS structure, caused by an electrodynamic force developed by the lightning current, can be evaluated by means of second order differential equations; the key factor being the ratio between the duration of the current impulse and the period of natural mechanical oscillation of the LPS structure. The typical condition encountered in LPS applications consists of natural oscillation periods of the structure much longer than that of the applied force (duration of the lightning current impulse). In this case the maximum mechanical stress occurs after the cessation of the current impulse and has a peak value that remains lower than that of the applied force. In most cases, maximum mechanical stress can be neglected.

Plastic deformation occurs when the tensile stress exceeds the elastic limit of the material. If the material composing the LPS structure is soft, for example aluminum or annealed copper, the electrodynamic forces can deform the conductors in corners and loops. LPS components should therefore be designed to withstand these forces and to show essentially an elastic behaviour.

The total mechanical stress applied to the LPS structure depends on the time integral of the applied force and therefore on the specific energy associated with the current impulse. It also depends on the waveshape of the current impulse and its duration (compared with the period of natural oscillation of the structure). All these influencing parameters must therefore be taken into account during testing.

D.4.2.2 Acoustic shock wave damage

When a lightning current flows in an arc, a shock wave is produced. The severity of the shock is dependent upon the peak current value and the rate of rise of the current.

In general, the damage due to the acoustic shock wave is insignificant on metal parts of the LPS, but can cause damage to surrounding items.

D.4.2.3 Combined effects

In practice, both thermal and mechanical effects occur simultaneously. If the heating of the material of the components (rods, clamps, etc.) is sufficient to soften the materials, much greater damage can occur than otherwise. In extreme cases, the conductor could explosively fuse and cause considerable damage to surrounding structure. If the cross-section of the metal is sufficient to safely handle the overall action, only mechanical integrity need be checked.

D.4.3 Sparking

In general, sparking becomes important only in flammable environments.: In most practical cases, sparking is not important for LPS components.

Two different types of sparking can occur, i.e. thermal sparking and voltage sparking. Thermal sparking occurs when a very high current is forced to cross a joint between two conducting materials. Most thermal sparking occur near the edges inside a joint if the interface pressure is too low; due primarily to high current density and inadequate interface pressure. The intensity of the thermal sparking is linked to the specific energy and therefore, the most critical phase of the lightning is the first return stroke. Voltage sparking occurs where the current is forced to take convoluted paths, e.g. inside a joint, if the voltage induced in such a loop exceeds the breakdown voltage between the metal parts. The induced voltage is proportional to the mutual inductance multiplied by the steepness of the lightning current. The most critical lightning component for voltage sparking is therefore the subsequent negative stroke.

D.5 LPS components, relevant problems and test parameters

Lightning protection systems are made of several different components, each having a specific function within the system. The nature of the components and the specific stresses to which they are subjected, requires special consideration when setting up laboratory tests to check their performance.

D.5.1 Air-termination

Effects on air-termination systems arise from both mechanical and thermal effects (as discussed below in D.5.2, but noting that a high proportion of the lightning current will flow in an air-termination conductor which is struck) and also in some cases arc erosion effects, particularly in natural LPS components such as thin metal roof skins (where puncture or excessive rear surface temperature rise may occur) and suspended conductors.

For arc erosion effects, two main test parameters should be considered: i.e. the charge of the long duration current and its duration.

The charge governs the energy input at the arc root. In particular, long duration strokes appear to be the most severe for this effect whilst short duration strokes can be neglected.

The duration of the current has an important role in the heat transfer phenomena into the material. The duration of the current applied during the tests shall be comparable to those of long duration strokes (0,5 s to 1 s).

D.5.2 Down conductors

Effects on down conductors caused by lightning can be divided into two main categories:

- thermal effects due to resistive heating;
- mechanical effects linked with the magnetic interaction where the lightning current is shared by conductors positioned in the vicinity of one another or when the current changes direction (bends or connections between conductors positioned at a given angle with respect to one another).

In most cases these two effects act independently from each other and separate laboratory tests can be carried out to check each effect. This approach can be adopted in all cases in which the heating developed by the lightning current flow does not modify substantially the mechanical characteristics.

D.5.2.1 Resistive heating

Calculations and measurements relating to the heating of conductors of different cross-sections and materials due to lightning current flowing along a conductor have been published by several authors. The main results in terms of plots and formulae are summarized in D.4.1.1. No laboratory test is therefore necessary, in general, to check the behaviour of a conductor with respect to temperature rise.

In all cases for which a laboratory test is required, the following considerations shall be taken into account.

The main test parameters to be considered in this case are the specific energy and the impulse current duration.

The specific energy governs the temperature rise due to the Joule heating caused by the flow of the lightning current. Numerical values to be considered are those relevant to the first stroke. Conservative data are obtained by considering positive strokes.

The impulse current duration has a decisive influence on the heat exchange process with respect to the ambient conditions surrounding the considered conductor. In most cases the duration of the impulse current is so short that the heating process can be considered adiabatic.

D.5.2.2 Mechanical effects

As discussed in D.4.2.1, mechanical interactions are developed between conductors carrying lightning current. The force is proportional to the product of the currents flowing in the conductors (or to the square of the current if a single bent conductor is considered) and is linked with the inverse of the distance between the conductors.

The usual situation in which a visible effect can occur is when a conductor forms a loop or is bent. When such a conductor carries the lightning current, it will be subjected to a mechanical force which tries to extend the loop and to straighten the corner and thus to bend it outward. The magnitude of this force is proportional to the square of the current amplitude. A clear distinction should be made, however, between the electrodynamic force, which is proportional to the square of the current amplitude, and the corresponding stress dependent on the elastic characteristics of the mechanical LPS structure. For LPS structures of relatively low natural frequencies, the stress developed within the LPS structure would be considerably lower than the electrodynamic force. In this case, no laboratory test is necessary to check the mechanical behaviour of a conductor bent at a right-angle as long as the cross-sectional areas of the present standard requirements are fulfilled.

In all cases for which a laboratory test is required (especially for soft materials), the following considerations shall be taken into account. Three parameters of the first return stroke are to be considered: the duration, the specific energy of the impulse current and, in the case of rigid systems, the amplitude of the current.

The duration of the impulse current, compared with the period of the natural mechanical oscillation of the LPS structure, governs the type of mechanical response of the system in terms of displacement:

- If the duration of the impulse is much shorter than the period of natural mechanical oscillation of the LPS structure (normal case for LPS structures stressed by lightning impulses), the mass and elasticity of the system prevents it from being displaced appreciably and the relevant mechanical stress is essentially related to the specific energy of the current impulse. The peak value of the impulse current has a limited effect.
- If the duration of the impulse is comparable with or higher than the period of natural mechanical oscillation of the structure, the displacement of the system is more sensitive to the waveshape of the applied stress. In this case, the peak value of the current impulse and its specific energy needs to be reproduced during the test.

The specific energy of the impulse current governs the stress causing the elastic and plastic deformation of the LPS structure. Numerical values to be considered are those relevant to the first stroke.

The maximum values of the impulse current govern the length of the maximum displacement of the LPS structure, in case of rigid systems, having high natural oscillation frequencies. Numerical values to be considered are those relevant to the first stroke.

D.5.3 Connecting components

Connecting components between adjacent conductors of an LPS are possible points of mechanical and thermal weakness where very high stresses occur.

In the case of a connector placed in such a manner as to make the conductor follow a right angle, the main effects of the stresses are linked with mechanical forces which tend to straighten the conductor set and resisting friction forces between the connecting component and the conductors pulling the connection apart. The development of arcs at the points of contact of the different parts is possible. Moreover, the heating effect caused by the concentration of current over small contact surfaces has a notable effect.

Laboratory tests have shown that it is difficult to separate each effect from one another as a complex synergism takes place. Mechanical strength is affected by local melting of the area of contact. Relative displacements between parts of the connection components promote the development of arcs and the consequential intense heat generation.

In the absence of a valid model, laboratory tests should be conducted in such a way as to represent as closely as possible the appropriate parameters of the lightning current in the most critical situation: i.e. the appropriate parameters of the lightning current shall be applied by means of a single electrical test.

Three parameters are to be considered in this case: the peak value, the specific energy and the duration of the impulse current.

The maximum values of the impulse current governs the maximum force, or, if and after the electrodynamic pulling force exceeds the friction force, the length of the maximum displacement of the LPS structure. Numerical values to be considered are those relevant to the first stroke. Conservative data are obtained by considering positive strokes.

The specific energy of the current impulse governs the heating at contact surfaces where the current is concentrated over small areas. Numerical values to be considered are those relevant to the first stroke. Conservative data are obtained by considering positive strokes.

The duration of the impulse current governs the maximum displacement of the structure after friction forces are exceeded and has an important role in the heat transfer phenomena into the material.

D.5.4 Earth termination

The real problems with earth termination electrodes are linked with chemical corrosion and mechanical damages caused by forces other than electrodynamic forces. In practical cases, erosion of the earth electrode at the arc root is of minor importance. It is, however, to be considered that, contrary to air terminations, a typical LPS has several earth terminations. The lightning current will be shared between several earthing electrodes, thus causing less important effects at the arc root.

Two main test parameters are to be considered in this case: the charge and duration of the long duration impulse current.

The charge governs the energy input at the arc root. In particular, the contribution of the first stroke can be neglected since long duration strokes appear to be the most severe for this component.

The duration of the current impulse has an important role in the heat transfer phenomena into the material. The duration of the current impulses applied during the tests shall be comparable to those of long duration strokes (0,5 s to 1s).

D.6 Surge protective device (SPD)

The effects of the stress on an SPD caused by lightning depend on the type of SPD considered, with particular reference to the presence or absence of a gap.

D.6.1 SPD containing spark gaps

Effects on spark gaps caused by lightning can be divided into two major categories:

- the erosion of the gap electrodes by heating, melting and vaporizing of material;
- the mechanical stress caused by the shock wave of the discharge.

It is extremely difficult to investigate separately these effects, as both are linked with the main lightning current parameters by means of complex relationships.

For spark gaps, laboratory tests shall be conducted in such a way as to represent as closely as possible the appropriate parameters of the lightning current in the most critical situation: i.e. all the appropriate parameters of the lightning current shall be applied by means of a single electrical stress.

Five parameters shall be considered in this case: the peak value, the charge, the duration, the specific energy and the rate of rise of the impulse current.

The current peak value governs the severity of the shockwave. Numerical values to be considered are those relevant to the first stroke. Conservative data are obtained by considering positive strokes.

The charge governs the energy input in the arc. The energy in the arc will heat up, melt and possibly vaporize part of the electrode material at the attachment point of the arc. Numerical values to be considered are those relevant to the whole lightning flash. However, the charge of the long duration current can be neglected in many cases, depending on the configuration of the power supply system (TN, TT or IT).

The duration of the impulse current governs the heat transfer phenomena into the mass of the electrode and the resulting propagation of the melt front.

The specific energy of the current impulse governs the self-magnetic compression of the arc and the physics of the electrode plasma jets developed at the interface between the electrode surface and the arc (which can blow out a significant amount of molten material). Numerical values to be considered are those relevant to the first stroke. Conservative data are obtained by considering positive strokes.

NOTE For spark gaps used on power supply systems, the possible power frequency follow current amplitude constitutes an important stress factor, which must be taken into consideration.

D.6.2 SPD containing metal-oxide varistors

Stress to metal-oxide varistors caused by lightning can be divided into two main categories: overload and flashover. Each category is characterized by failure modes generated by different phenomena and governed by different parameters. The failure of a metal-oxide SPD is linked with its weakest characteristics and therefore it is unlikely that synergism between different fatal stresses can occur. It appears, therefore, to be acceptable to carry out separate tests to check the behaviour under each failure mode condition.

Overloads are caused by an amount of absorbed energy exceeding the capabilities of the device. The excessive energy considered here is related to the lightning stress itself. However, for SPDs installed on power supply systems, the follow current injected in the device by the power system immediately after the cessation of the lightning current flow can also play an important role in the fatal damage of the SPD. Finally, an SPD can be fatally damaged by thermal instability under the applied voltage related to the negative temperature coefficient of the volt-ampere characteristics of the resistors. For the overload simulation of metal-oxide varistors, one main parameter is to be considered: the charge.

The charge governs the energy input into the metal-oxide resistors block, considering as a constant the residual voltage of the metal-oxide resistor block. Numerical values to be considered are those relevant to the lightning flash.

Flashovers and cracking are caused by the amplitude of current impulses exceeding the capabilities of the resistors. This failure mode is generally evidenced by an external flashover along the collar, sometimes penetrating into the resistor block causing a crack or a hole perpendicular to the collar. The failure is mainly linked with a dielectric collapse of the collar of the resistor block.

For the simulation of this lightning phenomenon, two main parameters are to be considered: the maximum value and the duration of the impulse current.

The maximum value of the impulse current determines, through the corresponding level of residual voltage, whether the maximum dielectric strength on the resistor collar is exceeded. Numerical values to be considered are those relevant to the first stroke. Conservative data are obtained by considering positive strokes.

The duration of the impulse current governs the duration of application of the dielectric stress on the resistor collar.

D.7 Summary of the test parameters to be adopted in testing LPS components

Table D.1 summarizes the most critical aspects of each LPS component during the performance of its function and gives the parameters of the lightning current to be reproduced in laboratory tests.

The numerical values given in Table D.1 are relevant to the lightning parameters of importance at the point of strike.

Test values are to be calculated considering the current sharing which can be expressed by means of the current sharing factor, as discussed in Clause D.3.

The numerical values of the parameters to be used during the tests can therefore be calculated on the base of the data given in Table D.1, applying the reduction factors linked with current sharing, as expressed by the formulae reported in Clause D.3.

Annex E (informative)

Surges due to lightning at different installation points

Overview

For dimensioning of conductors, SPDs and apparatus, the threat due to surges at the particular installation point of these components should be determined. Surges can arise from (partial) lightning currents and from induction effects into installation loops. The threat due to these surges must be lower than the withstand of the components used (defined by adequate tests as necessary).

E.1 Surges due to flashes to the structure (source of damage S1)

E.1.1 Surges flowing through external conductive parts and lines connected to the structure

When conducted to earth, the lightning current is divided between the earth termination system, the external conductive parts and the lines, directly or via SPDs connected to them.

If $I_f = k_e I$ (E.1)

is the part of the lightning current relevant to each external conductive part or line, then k_e depends on:

- the number of parallel paths;
- their conventional earthing impedance for underground parts, or their earth resistance, where overhead parts connect to underground, for overhead parts,
- the conventional earthing impedance of the earth-termination system.

- for underground installation
$$k_e = \frac{Z}{Z_1 + Z(n_1 + n_2 \frac{Z_1}{Z_2})}$$
 (E.2)

- for overhead installation
$$k_e = \frac{Z}{Z_2 + Z(n_2 + n_1 \frac{Z_2}{Z_1})}$$
 (E.3)

where

Z is the conventional earthing impedance of the earth-termination system;

Z_1 is the conventional earthing impedance of the external parts or lines (Table E.1) running underground;

Z_2 is the earth resistance of the earthing arrangement connecting the overhead line to ground. If the earth resistance of the earthing point is not known, the value of Z_1 shown in Table E.1 may be used (where the resistivity is relevant to the earthing point).

NOTE This value is assumed in the above formula to be the same for each earthing point. If this is not the case, more complex equations need to be used.

n_1 is the overall number of external parts or lines running underground;

n_2 is the overall number of external parts or lines running overhead;

I is the lightning current relevant to the LPS class considered.

Assuming as first approximation that one half of the lightning current flows in the earth termination system and that $Z_2 = Z_1$, the value of k_e may be evaluated for an external conductive part or line by:

$$k_e = 0,5 / (n_1 + n_2) \quad (\text{E.4})$$

If entering lines (e.g. electrical and telecommunication lines) are unshielded or not routed in metal conduit, each of the n' conductors of the line carries an equal part of the lightning current

$$k'_e = k_e / n' \quad (\text{E.5})$$

n' being the total number of conductors.

For shielded lines bonded at the entrance, the values of current k'_e for each of the n' conductors of a shielded service are given by:

$$k'_e = k_e \cdot R_s / (n' \cdot R_s + R_c) \quad (\text{E.6})$$

with

R_s ohmic resistance per unit length of shield;

R_c ohmic resistance per unit length of inner conductor.

NOTE 3 This formula may underestimate the role of the shield in diverting lightning current due to mutual inductance between core and shield.

Table E.1 – Conventional earthing impedance values Z and Z_1 according to the resistivity of the soil

ρ Ωm	Z_1 Ω	Conventional earthing impedance related to the class of LPS		
		Z Ω		
		I	II	III – IV
≤100	8	4	4	4
200	11	6	6	6
500	16	10	10	10
1 000	22	10	15	20
2 000	28	10	15	40
3 000	35	10	15	60

NOTE Values reported in this table refer to the conventional earthing impedance of a buried conductor under impulse condition (10/350 μs).

E.1.2 Factors influencing the sharing of the lightning current in power lines

For detailed calculations several factors can influence the amplitude and the waveshape of such surges:

- the cable length can influence current sharing and waveshape characteristics due to the L/R ratio;
- different impedances of neutral and phase conductors can influence current sharing among line conductors;

NOTE For example, if the neutral (N) conductor has multiple grounds, the lower impedance of N compared with L1, L2, and L3 could result in 50 % of the current flowing through the N conductor with the remaining 50 % being shared by the other 3 lines (17 % each). If N, L1, L2, and L3 have the same impedance, each conductor will carry approximately 25 % of the current.

- different transformer impedances can influence current sharing (this effect is negligible, if the transformer is protected by SPDs bypassing its impedance);
- the relation between the conventional earthing resistances of the transformer and the items on the load side can influence current sharing (the lower the transformer impedance, the higher is the surge current flowing into the low voltage system);
- parallel consumers cause a reduction of the effective impedance of the low voltage system which may increase the partial lightning current flowing into this system.

E.2 Surges relevant to services connected to the structure

E.2.1 Surges due to flashes to services (source of damage S3)

For direct lightning flashes to connected services, partitioning of the lightning current in both directions of the service and the breakdown of insulation must be taken into account.

The selection of the I_{imp} value can be based on values given in Table E.2 where the preferred values of I_{imp} are associated with the lightning protection level (LPL).

Table E.2 – Expected surge overcurrents due to lightning flashes

	Low voltage systems			Telecommunication lines		
	Flash to the service	Flash near the service	Near to, or on the structure	Flash to the service	Flash near the service	Near to, or on the structure
LPL	Source of damage S3 (direct flash) Waveform: 10/350 μ s (kA)	Source of damage S4 (indirect flash) Waveform: 8/20 μ s (kA)	Source of damage S1 or S2 (induced current only for S1) Waveform: 8/20 μ s (kA)	Source of damage S3 (direct flash) waveform: 10/350 μ s (kA)	Source of damage S4 (indirect flash) measured: 5/300 μ s (estimated: 8/20 μ s) (kA)	Source of damage S2 (induced current) Waveform: 8/20 μ s (kA)
III-IV	5	2,5	0,1	1	0,01 (0,05)	0,05
I-II	10	5	0,2	2	0,02 (0,1)	0,1

For shielded lines, the values of the overcurrents given in Table E.2 can be reduced by a factor of 0,5.

NOTE It is assumed that the resistance of the shield is approximately equal to the resistance of all service conductors in parallel.

E.2.2 Surges due to flashes near the services (Source of damage S4)

Surges from flashes near services have energies much lower than those associated with flashes to services (source of damage S3).

Expected overcurrents, associated with a specific lightning protection level (LPL) are given in Table E.2.

For shielded lines the values of overcurrents given in Table E.2 can be reduced by a factor 0,5.

E.3 Surges due to induction effects (Source of damage S1 or S2)

Surges due to induction effects from magnetic fields, generated either from nearby lightning flashes (source S2) or from lightning current flowing in the external LPS or the spatial shield of LPZ 1 (source S1) have a typical current waveform of 8/20 μ s. Such surges are to be considered close to or at the terminal of apparatus inside of LPZ 1 and at the boundary of LPZ 1/2.

E.3.1 Surges inside of an unshielded LPZ 1

Inside an unshielded LPZ 1 (e.g. protected only by an external LPS according to IEC 62305-3 with mesh width greater than 5 m) relatively high surges are to be expected due the induction effects from the non damped magnetic field.

Expected overcurrents, associated with a specific lightning protection level (LPL) are given in Table E.2.

E.3.2 Surges inside shielded LPZs

Inside of LPZs with effective spatial shielding (requiring mesh width below 5m according to Annex A of IEC 62305-4), the generation of surges due to induction effects from magnetic fields is strongly reduced. In such cases the surges are much lower than those given in E.3.1.

Inside LPZ 1 the induction effects are lower due to the damping effect of its spatial shield.

Inside LPZ 2 the surges are further reduced due to the cascaded effect of both spatial shields of LPZ 1 and LPZ 2.

E.4 General information relating to SPDs

The use of SPDs depends on their withstand capability, classified in IEC 61643-1 ^[6] for power and in IEC 61643-21 for telecommunication systems.

SPDs to be used according to their installation position are as follows:

- a) At the line entrance into the structure (at the boundary of LPZ 1, e.g. at the main distribution board MB):
 - SPD tested with I_{imp} (typical waveform 10/350, e.g. SPD tested according to Class I);
 - SPD tested with I_n (typical waveform 8/20, e.g. SPD tested according to Class II).

- b) Close to the apparatus to be protected (at the boundary of LPZ 2 and higher, e.g. at secondary distribution board SB, or at a socket outlet SA):
- SPD tested with I_n (typical waveform 8/20, e.g. SPD tested according to Class II);
 - SPD tested with a combination wave (typical current waveform 8/20, e.g. SPD tested according to Class III).

Bibliography

- [1] IEC 60664-1:1992, *Insulation coordination for equipment within low-voltage systems – Part 1: Principles, requirements and tests*
 - [2] IEC 61000-4-5:1995, *Electromagnetic compatibility (EMC) – Part 4-5: Testing and measurement techniques – Surge immunity test*
 - [3] Berger K., Anderson R.B., Kröninger H., *Parameters of lightning flashes*. CIGRE Electra No 41 (1975), p. 23 – 37
 - [4] Anderson R.B., Eriksson A.J., *Lightning parameters for engineering application*. CIGRE Electra No 69(1980), p. 65 - 102
 - [5] IEEE working group report, *Estimating lightning performance of transmission lines II*, 1992
 - [6] IEC 61643-1:2005, *Low-voltage surge protective devices – Part 1: Surge protective devices connected to low-voltage power distribution systems – Requirements and tests*
 - [7] IEC 61643-12:2002: *Low-voltage surge protective devices – Part 12: Surge protective devices connected to low voltage power distribution systems – Selection and application principles*
-

ISBN 2-8318-XXXX-X

ICS 29.020; 91.120.40

Typeset and printed by the IEC Central Office
GENEVA, SWITZERLAND